

TRAFFIC IMPACT ANALYSIS REPORT  
**HARDT AND BRIER BUSINESS PARK PROJECT**  
San Bernardino, California  
May 12, 2023  
(Revision of April 7, 2022 Report)

*Prepared for:*

**Oak Properties**  
9747 Businesspark Avenue  
San Diego, CA 92131

LLG Ref. 2-21-4502-1



*Prepared by:*  
Megan Lam  
Transportation Engineer II  
and  
Daniel A. Kloos, P.E.  
Associate Principal



*Under the Supervision of:*  
Keil D. Maberry, P.E.  
Principal

**Linscott, Law &  
Greenspan, Engineers**

2 Executive Circle  
Suite 250

Irvine, CA 92614

949.825.6175 T

949.825.6173 F

www.llgengineers.com

# TABLE OF CONTENTS

SECTION	PAGE
<b>Executive Summary .....</b>	<b>vi</b>
<b>1.0 Introduction.....</b>	<b>1</b>
1.1 Study Area.....	2
1.2 Traffic Impact Analysis Components.....	2
1.3 Traffic Impact Analysis Scenarios .....	3
<b>2.0 Project Description and Location.....</b>	<b>4</b>
2.1 Site Access .....	4
<b>3.0 Analysis Conditions and Methodology .....</b>	<b>5</b>
3.1 Existing Street Network .....	5
3.2 Existing Traffic Volumes .....	6
3.3 Level of Service (LOS) Analysis Methodologies .....	6
3.3.1 Highway Capacity Manual 7 (HCM 7) Method of Analysis (Signalized Intersections).....	6
3.3.2 Highway Capacity Manual 7 (HCM 7) Method of Analysis (Unsignalized Intersections).....	6
3.3.2.1 Two-Way Stop-Controlled Intersections .....	7
3.3.2.2 All-Way Stop-Controlled Intersections .....	7
3.4 Impact Criteria and Thresholds .....	7
3.4.1 City of San Bernardino .....	7
3.4.2 City of Loma Linda.....	8
<b>4.0 Traffic Forecasting Methodology .....</b>	<b>12</b>
<b>5.0 Project Traffic Characteristics .....</b>	<b>13</b>
5.1 Project Trip Generation Forecast .....	13
5.2 Project Trip Distribution and Assignment.....	13
<b>6.0 Future Traffic Conditions .....</b>	<b>15</b>
6.1 Existing With Project Traffic Volumes.....	15
6.2 Year 2025 Without Project Traffic Volumes .....	15
6.2.1 Ambient Growth Traffic .....	15
6.2.2 Cumulative Projects Traffic.....	15
6.3 Year 2025 With Project Traffic Volumes .....	16
6.4 Buildout Traffic Conditions .....	16
6.4.1 Volume Adjustment.....	16
6.4.2 B-turn Methodology.....	16
6.5 Buildout Traffic Volumes .....	17

## TABLE OF CONTENTS (CONTINUED)

SECTION	PAGE
<b>7.0 Existing With Project Analysis</b> .....	<b>23</b>
7.1 Existing Traffic Conditions .....	23
7.2 Existing With Project Traffic Conditions.....	23
<b>8.0 Year 2025 With Project Analysis</b> .....	<b>25</b>
8.1 Year 2025 Without Project Traffic Conditions .....	25
8.2 Year 2025 With Project Traffic Conditions .....	25
<b>9.0 Buildout With Project Analysis</b> .....	<b>27</b>
9.1 Buildout Without Project Traffic Conditions .....	27
9.2 Buildout With Project Traffic Conditions .....	27
<b>10.0 Site Access and Internal Circulation Evaluation</b> .....	<b>29</b>
10.1 Site Access .....	29
10.2 Internal Circulation Evaluation .....	29
<b>11.0 Caltrans Facilities Analysis</b> .....	<b>31</b>
11.1 Ramp Intersection Capacity Analysis .....	31
<b>12.0 Recommended Improvements</b> .....	<b>32</b>
12.1 Existing With Project Traffic Conditions.....	32
12.2 Year 2025 With Project Traffic Conditions .....	32
12.3 Buildout With Project Traffic Conditions .....	32
<b>13.0 Vehicle Miles Traveled (VMT) Analysis</b> .....	<b>33</b>
13.1 VMT Analysis Conclusion .....	35

## APPENDICES

---

### APPENDIX

---

- A. Traffic Study Scope of Work**
- B. Existing Traffic Count Data**
- C. Modeling Worksheets**
- D. Existing Traffic Conditions Intersection Level of Service Calculation Worksheets**
  - D-I Existing Traffic Conditions
  - D-II Existing With Project Traffic Conditions
- E. Year 2025 Traffic Conditions Intersection Level of Service Calculation Worksheets**
  - E-I Year 2025 Without Project Traffic Conditions
  - E-II Year 2025 With Project Traffic Conditions
- F. Buildout Traffic Conditions Intersection Level of Service Calculation Worksheets**
  - F-I Buildout Without Project Traffic Conditions
  - F-II Buildout With Project Traffic Conditions
- G. Project Driveway Level of Service Calculation Worksheets**
  - G-I Year 2025 With Project Traffic Conditions
  - G-II Buildout With Project Traffic Conditions
- H. SBCTA VMT Screening Tool Data**

## LIST OF FIGURES

SECTION – FIGURE #	FOLLOWING PAGE
1–1 Vicinity Map .....	3
2–1 Existing Site Aerial .....	4
2–2 Proposed Site Plan.....	4
3–1 Existing Roadway Conditions and Intersection Controls .....	6
3–2 City of San Bernardino General Plan Circulation Element.....	6
3–3 Existing AM Peak Hour Traffic Volumes.....	6
3–4 Existing PM Peak Hour Traffic Volumes .....	6
5–1 Project Traffic Distribution Pattern (Buildings A and B).....	14
5–2 Project Traffic Distribution Pattern (Building C).....	14
5–3 Project Traffic Distribution Pattern (Buildings D1 and D2).....	14
5–4 Project Traffic Distribution Pattern (Building E) .....	14
5–5 AM Peak Hour Project Traffic Volumes.....	14
5–6 PM Peak Hour Project Traffic Volumes .....	14
6–1 Existing With Project AM Peak Hour Traffic Volumes .....	22
6–2 Existing With Project PM Peak Hour Traffic Volumes.....	22
6–3 Location of Cumulative Projects .....	22
6–4 AM Peak Hour Cumulative Projects Traffic Volumes .....	22
6–5 PM Peak Hour Cumulative Projects Traffic Volumes.....	22
6–6 Year 2025 Without Project AM Peak Hour Traffic Volumes.....	22
6–7 Year 2025 Without Project PM Peak Hour Traffic Volumes .....	22
6–8 Year 2025 With Project AM Peak Hour Traffic Volumes.....	22
6–9 Year 2025 With Project PM Peak Hour Traffic Volumes.....	22
6–10 Buildout Without Project AM Peak Hour Traffic Volumes .....	22
6–11 Buildout Without Project PM Peak Hour Traffic Volumes .....	22
6–12 Buildout With Project AM Peak Hour Traffic Volumes.....	22
6–13 Buildout With Project PM Peak Hour Traffic Volumes .....	22

## LIST OF TABLES

SECTION-TABLE#	PAGE
3-1	Level of Service Criteria For Signalized Intersections (HCM 7 Methodology)..... 10
3-2	Level of Service Criteria For Unsignalized Intersections (HCM 7 Methodology) ..... 11
5-1	Project Traffic Generation Rates and Forecast..... 14
6-1	Location and Description of Cumulative Projects ..... 18-20
6-2	Cumulative Projects Traffic Generation Forecast..... 21-22
7-1	Existing With Project Conditions Peak Hour Intersection Capacity Analysis Summary ..... 24
8-1	Year 2025 With Project Conditions Peak Hour Intersection Capacity Analysis Summary ..... 26
9-1	Buildout With Project Conditions Peak Hour Intersection Capacity Analysis Summary ..... 28
10-1	Project Driveway Peak Hour Levels of Service Summary..... 30

# EXECUTIVE SUMMARY

## **Project Description**

- The project site is generally located west of Tippecanoe Avenue, north of Hardt Street and between Hardt Street and Brier Drive in the City of San Bernardino, California. The proposed Project will consist of a business park totaling a maximum of 108,500 square-feet (SF) amongst six (6) proposed buildings with a total of 280 parking spaces. Building A will consist of 17,900 SF (including 1,300 SF of mezzanine), Building B will consist of 17,600 SF (including 1,300 SF of mezzanine), Building C will consist of 18,400 SF (including 1,300 SF of mezzanine), Building D1 will consist of 13,800 SF, Building D2 will consist of 13,800 SF and Building E will consist of 27,000 SF (including 1,300 SF of mezzanine). There will be approximately 150-250 employees amongst the six (6) buildings. The Project is anticipated to be completed by the Year 2025. Please note that the Traffic Impact Analysis Report was prepared using a previous version of the site plan in which an additional 6<sup>th</sup> building totaling 27,000 SF was included, which brought the total project building area to 108,500 SF. Thus, the analysis contained herein is more conservative than the proposed project, which includes five (5) service commercial buildings totaling 81,500 SF.

Vehicular access to Buildings A, B and C will be provided via unsignalized driveways located along Hardt Street (referred to as Project Driveways No. 1, No. 2, No. 3, No. 4 and No. 5). Project Driveways No. 1, No. 2, No. 3, No. 4 and No. 5 will all be full access driveways. Vehicular access to Buildings D1, D2 and E will be provided via unsignalized driveways located along Brier Drive (referred to as Project Driveways No. 6, No. 7, No. 8, No. 9 and No. 10). Project Driveway No. 8 will be a full access driveway. Project Driveways No. 6, No. 7, No. 9 and No. 10 will be right-turn in/right-turn out only access driveways.

- The proposed Project is forecast to generate approximately 1,350 daily trips, with 146 trips (124 inbound, 22 outbound) produced in the AM peak hour and 132 trips (35 inbound, 97 outbound) produced in the PM peak hour on a “typical” weekday.

## **Study Area**

- Five (5) key study intersections were selected for evaluation based on discussions with City of San Bernardino Public Works Department staff. The intersections listed below provide local access to the study area and define the extent of the boundaries for this traffic impact investigation. The jurisdiction where each key study intersection is located is also identified.

### **Key Study Intersections:**

1. Tippecanoe Avenue at Hardt Street (San Bernardino)
2. Tippecanoe Avenue at Brier Drive/Gould Street (San Bernardino)
3. Tippecanoe Avenue at Hospitality Lane/Coulston Street (San Bernardino)
4. Tippecanoe Avenue at Harriman Place/I-10 Westbound Ramps (San Bernardino)
5. Tippecanoe Avenue/Anderson Street at I-10 Eastbound Ramps (Loma Linda/Caltrans)

## **Cumulative Projects Description**

- The thirty-three (33) cumulative projects are expected to generate 47,556 daily trips (one half arriving, one half departing), with 4,673 trips (2,609 inbound and 2,064 outbound) forecast during the AM peak hour and 3,707 trips (1,708 inbound and 1,999 outbound) forecast during the PM peak hour on a “typical” weekday.

## **Traffic Impact Analysis**

### *Existing Traffic Conditions*

- For Existing traffic conditions, all five (5) key study intersections currently operate at acceptable LOS C or better during the AM and PM peak hours when compared to the LOS standards defined in this report.

### *Existing With Project Traffic Conditions*

- The proposed Project ***will not*** cause an operational deficiency at the five (5) key study intersections when compared to the LOS criteria defined in this report. The five (5) key study intersections currently operate and are forecast to continue to operate at an acceptable LOS during the AM and PM peak hours with the addition of Project generated traffic to existing traffic.

### *Year 2025 With Project Traffic Conditions*

- The proposed Project ***will not*** cause an operational deficiency at the five (5) key study intersections when compared to the LOS criteria defined in this report. The five (5) key study intersections are forecast to continue to operate at an acceptable LOS D or better during the AM and PM peak hours with the addition of Project generated traffic in the horizon Year 2025.

### *Buildout With Project Traffic Conditions*

- The proposed Project ***will not*** cause an operational deficiency at the five (5) key study intersections when compared to the LOS criteria defined in this report. The five (5) key study intersections are forecast to continue to operate at an acceptable LOS D or better during the AM and PM peak hours with the addition of Project generated traffic added to Buildout traffic conditions.

## **Site Access and Internal Circulation Evaluation**

- The ten (10) Project driveways are forecast to operate at acceptable LOS B or better during the AM and PM peak hours for Year 2025 With Project traffic conditions and Buildout With Project traffic conditions. As such, project access will be adequate.



- The on-site circulation layout of the proposed Project on an overall basis is adequate. Curb return radii have been confirmed and are generally adequate for small and large service/delivery (FedEx, UPS, tractor-trailers) trucks.

### **Caltrans Facilities Analysis**

- The two (2) state-controlled study intersections are forecast to operate at an acceptable LOS D or better during the AM peak hour and PM peak hour without and with the proposed Project for all analyzed traffic conditions.

### **Recommended Improvements**

#### *Existing With Project Traffic Conditions*

- The results of the Existing With Project traffic conditions level of service analyses indicate that the proposed Project ***will not*** impact any of the five (5) key study intersections. All five (5) key study intersections are forecast to operate at acceptable service levels under Existing With Project traffic conditions. As such, no improvement measures have been recommended.

#### *Year 2025 With Project Traffic Conditions*

- The results of the Year 2025 With Project traffic conditions level of service analyses indicate that the proposed Project ***will not*** impact any of the five (5) key study intersections. All five (5) key study intersections are forecast to operate at acceptable service levels under Year 2025 With Project traffic conditions. As such, no improvement measures have been recommended.

#### *Buildout With Project Traffic Conditions*

- The results of the Buildout With Project traffic conditions level of service analyses indicate that the proposed Project ***will not*** impact any of the five (5) key study intersections. All five (5) key study intersections are forecast to operate at acceptable service levels under Buildout With Project traffic conditions. As such, no improvement measures have been recommended.

### **Vehicle Miles Traveled (VMT) Analysis**

- *Based on the SBCTA screening tool, the project site is located within a Transit Priority Area (TPA). Although the proposed Project has a Floor Area Ratio (FAR) less than 0.75, the Project is a large development with many employees (i.e. approximately 150-250 employees amongst the six buildings) that would likely utilize transit and significantly benefit from being located within a TPA from a VMT reduction standpoint. Whereas a smaller project with a low FAR and a limited number of employees or population may not take advantage of the TPA. The proposed Project will provide a total of 280 parking spaces amongst the six buildings, which is less than City-code parking requirements. The proposed Project is*

*consistent with the Sustainable Communities Strategy and does not replace affordable housing. Consequently, the proposed Project satisfies all four of the TPA criteria. As a result, based on the Step 1: Transit Priority Area (TPA) Screening criteria, this project could be screened from a VMT analysis, and could be presumed to have a less than significant impact on VMT per the City's guidelines.*

- *Based on the SBCTA screening tool, the project site (all six proposed buildings) is located within Traffic Analysis Zone (TAZ) #53807502. Per the SBCTA screening tool (Baseline Year 2016), the Project TAZ VMT/service population is 71.8 VMT per service population and the City average VMT/service population is 29.6 VMT per service population. Comparison of the two VMT values indicates that the Project TAZ VMT is higher than the City VMT average. Therefore, Project Screening Step 2: Low VMT Area Screening is not satisfied.*
- *The proposed Project will consist of a business park totaling a maximum of 108,500 SF and is forecast to generate approximately 1,350 daily trips, which are both greater than the aforementioned development size and daily trip thresholds. Therefore, Project Screening Step 3: Project Type Screening is not satisfied.*
- *Based on the City's guidelines, the proposed Project, which consists of a maximum of 103,300 SF business park, satisfies Step 1: Transit Priority Area (TPA) Screening. Therefore, this project could be screened from a VMT analysis, and could be presumed to have a less than significant impact on VMT per the City's guidelines.*

TRAFFIC IMPACT ANALYSIS REPORT  
**HARDT AND BRIER BUSINESS PARK PROJECT**  
San Bernardino, California  
May 12, 2023  
(Revision of April 7, 2022 Report)

## 1.0 INTRODUCTION

This traffic impact analysis evaluates the potential traffic impacts and circulation needs associated with the proposed Hardt and Brier Business Park Project (hereinafter referred to as Project). The project site is generally located west of Tippecanoe Avenue, north of Hardt Street and between Hardt Street and Brier Drive in the City of San Bernardino, California. The proposed Project will consist of a business park totaling a maximum of 108,500 square-foot (SF) amongst six (6) proposed buildings with a total of 280 parking spaces. Building A will consist of 17,900 SF (including 1,300 SF of mezzanine), Building B will consist of 17,600 SF (including 1,300 SF of mezzanine), Building C will consist of 18,400 SF (including 1,300 SF of mezzanine), Building D1 will consist of 13,800 SF, Building D2 will consist of 13,800 SF and Building E will consist of 27,000 SF (including 1,300 SF of mezzanine)<sup>1</sup>. The Project is anticipated to be completed by the Year 2025. Vehicular access to Buildings A, B and C will be provided via driveways located along Hardt Street. Vehicular access to Buildings D and E will be provided via driveways located along Brier Drive.

This report documents the findings and recommendations of a traffic impact analysis conducted by Linscott, Law & Greenspan, Engineers (LLG) to determine the potential traffic impacts that the Project may have on the local and/or regional transportation network in the vicinity of the Project site. The traffic impact analysis evaluates the operating conditions at five (5) existing key study intersections within the Project vicinity, estimates the trip generation potential of the Project and forecasts future (near-term and long-term) operating conditions without and with the Project.

This traffic report satisfies the *City of San Bernardino Traffic Impact Analysis Guidelines*, dated August 2020, and is consistent with the most current *Congestion Management Program (CMP) for San Bernardino County*. The Scope of Work for this traffic study, which is included in **Appendix A**, was developed in conjunction with City of San Bernardino Public Works Department staff.

The project site has been visited and an inventory of adjacent area roadways and intersections was performed. Existing (i.e. baseline) AM and PM peak hour traffic information has been collected at five (5) key study intersections on a “typical” weekday for use in the preparation of intersection level of service calculations. Information concerning cumulative projects (planned and/or approved) in the vicinity of the proposed Project has been researched at the City of San Bernardino, the City of Loma Linda, the City of Redlands and the City of Highland. Based on our research, there are twenty-three (23) cumulative projects in the City of San Bernardino, eight (8) cumulative projects in

---

<sup>1</sup> Please note that the Traffic Impact Analysis Report was prepared using a previous version of the site plan in which an additional 6<sup>th</sup> building totaling 27,000 SF was included, which brought the total project building area to 108,500 SF. Thus, the analysis contained herein is more conservative than the proposed project, which includes five (5) service commercial buildings totaling 81,500 SF.

the City of Loma Linda, one (1) cumulative project in the City of Redlands and one (1) cumulative project in the City of Highland within the vicinity of the subject site. These thirty-three (33) planned and/or approved cumulative projects were considered in the cumulative traffic analysis for this project.

This traffic report analyzes existing and future weekday AM peak hour and PM peak hour traffic conditions for a near-term (Year 2025 – Project Opening Year) and long-term (Buildout) traffic setting upon completion of the proposed Project. Peak hour traffic forecasts for the Year 2025 horizon year have been projected by increasing existing traffic volumes by an annual growth rate of three percent (3.0%) per year and adding traffic volumes generated by thirty-three (33) cumulative projects. Long-term (Buildout) peak hour traffic forecasts were projected based on modeled traffic projections utilizing the San Bernardino Traffic Analysis Model (SBTAM).

## 1.1 Study Area

Five (5) key study intersections were selected for evaluation based on discussions with City of San Bernardino Public Works Department staff. The intersections listed below provide local access to the study area and define the extent of the boundaries for this traffic impact investigation. The jurisdiction where each key study intersection is located is also identified.

### **Key Study Intersections:**

1. Tippecanoe Avenue at Hardt Street (San Bernardino)
2. Tippecanoe Avenue at Brier Drive/Gould Street (San Bernardino)
3. Tippecanoe Avenue at Hospitality Lane/Coulston Street (San Bernardino)
4. Tippecanoe Avenue at Harriman Place/I-10 Westbound Ramps (San Bernardino)
5. Tippecanoe Avenue/Anderson Street at I-10 Eastbound Ramps (Loma Linda/Caltrans)

## 1.2 Traffic Impact Analysis Components

The Highway Capacity Manual (HCM) Delay, Volume to Capacity (V/C) ratio and corresponding Level of Service (LOS) calculations at the key study locations were used to evaluate the potential traffic-related impacts associated with area growth, cumulative projects and the Project. When necessary, this report recommends intersection improvements that may be required to accommodate future traffic volumes and restore/maintain an acceptable Level of Service and/or addresses the impact of the Project.

Included in this Traffic Impact Analysis are:

- Existing Traffic Counts,
- Estimated Project traffic generation/distribution/assignment,
- Estimated Cumulative Projects traffic generation/distribution/assignment,
- AM and PM peak hour LOS analyses for Existing (i.e. Baseline) Conditions,
- AM and PM peak hour for Existing (i.e. Baseline) Conditions with Project traffic,

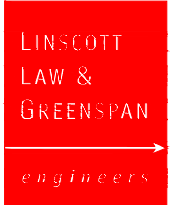
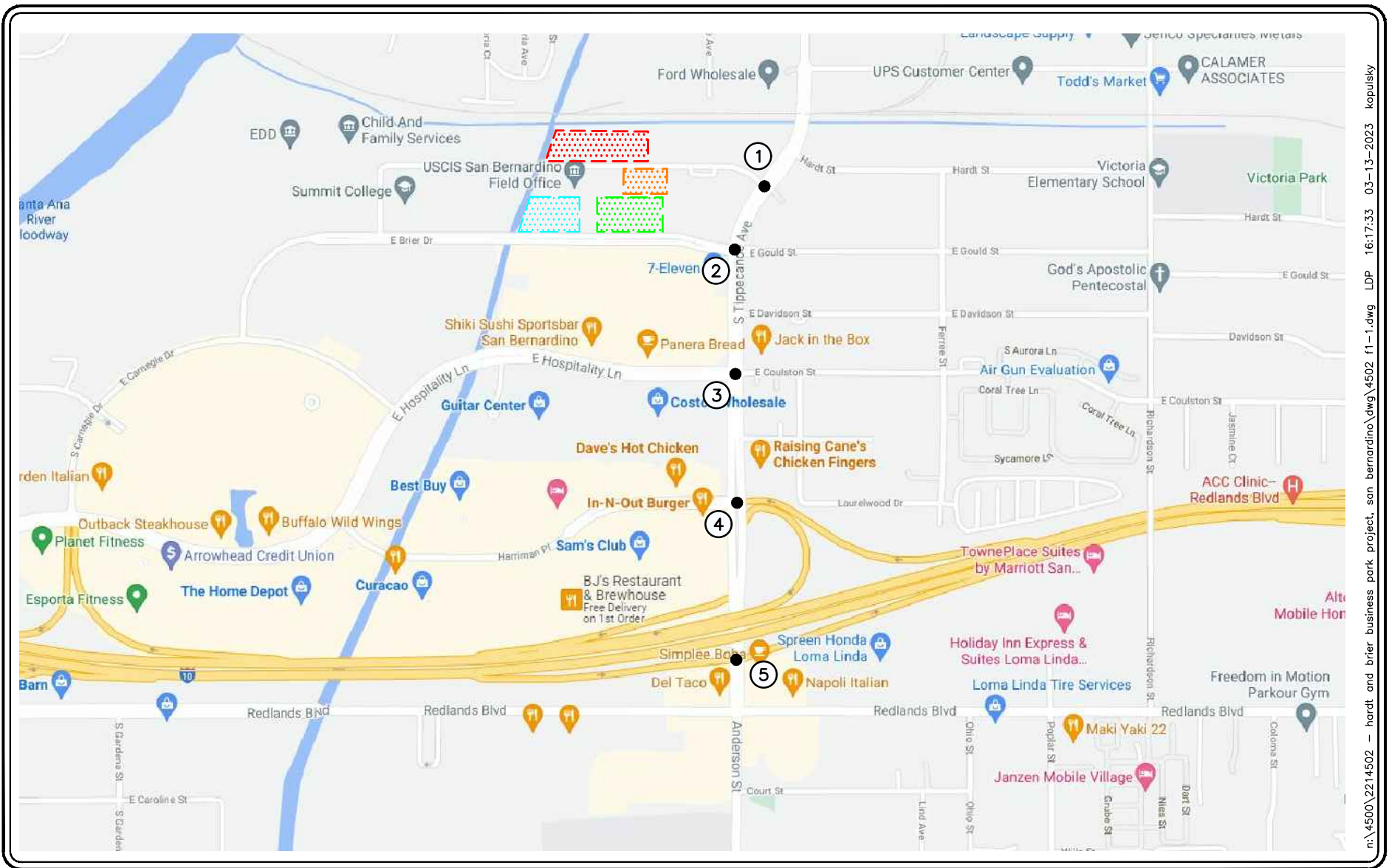
- AM and PM peak hour LOS analyses for Near-Term (Year 2025) Conditions without and with Project traffic,
- AM and PM peak hour LOS analyses for Buildout Conditions without and with Project traffic,
- Site Access and Internal Circulation Evaluation,
- Caltrans Facilities Analysis,
- Recommended Improvements (if any), and
- Vehicle Miles Traveled (VMT) Assessment.

*Figure 1-1* presents a Vicinity Map, which illustrates the general location of the Project and depicts the study locations and surrounding street system.

### 1.3 Traffic Impact Analysis Scenarios






The following scenarios are those for which volume/capacity and corresponding LOS calculations have been performed at the five (5) key study intersections for existing, near-term and buildout traffic conditions:

1. Existing (i.e. Baseline) Traffic Conditions;
2. Existing (i.e. Baseline) With Project Traffic Conditions;
3. Scenario (2) with Recommended Improvements, if any;
4. Year 2025 Without Project Traffic Conditions;
5. Year 2025 With Project Traffic Conditions;
6. Scenario (5) With Recommended Improvements, if any;
7. Buildout Without Project Traffic Conditions;
8. Buildout With Project Traffic Conditions; and
9. Scenario (8) With Recommended Improvements, if any.



SOURCE: GOOGLE

KEY

-  = STUDY INTERSECTION
-  = BUILDINGS A & B
-  = BUILDING C
-  = BUILDINGS D1 & D2
-  = BUILDING E

# FIGURE 1-1

## VICINITY MAP

HARDT AND BRIER BUSINESS PARK PROJECT, SAN BERNARDINO

## 2.0 PROJECT DESCRIPTION AND LOCATION

The project site is generally located west of Tippecanoe Avenue, north of Hardt Street and between Hardt Street and Brier Drive in the City of San Bernardino, California. The proposed Project will consist of a business park totaling a maximum of 108,500 SF amongst six (6) proposed buildings with a total of 280 parking spaces. Building A will consist of 17,900 SF (including 1,300 SF of mezzanine), Building B will consist of 17,600 SF (including 1,300 SF of mezzanine), Building C will consist of 18,400 SF (including 1,300 SF of mezzanine), Building D1 will consist of 13,800 SF, Building D2 will consist of 13,800 SF and Building E will consist of 27,000 SF (including 1,300 SF of mezzanine). There will be approximately 150-250 employees amongst the six (6) buildings. The Project is anticipated to be completed by the Year 2025.

*Figure 2-1* presents an aerial image of the existing site for the proposed Project. *Figure 2-2* presents the site plan for the proposed Project.

Please note that the Traffic Impact Analysis Report was prepared using a previous version of the site plan in which an additional 6<sup>th</sup> building totaling 27,000 SF was included, which brought the total project building area to 108,500 SF. Thus, the analysis contained herein is more conservative than the proposed project, which includes five (5) service commercial buildings totaling 81,500 SF.

### 2.1 Site Access

As shown on *Figure 2-2*, vehicular access to Buildings A, B and C will be provided via unsignalized driveways located along Hardt Street (referred to as Project Driveways No. 1, No. 2, No. 3, No. 4 and No. 5). Project Driveways No. 1, No. 2, No. 3, No. 4 and No. 5 will all be full access driveways. Vehicular access to Buildings D1, D2 and E will be provided via unsignalized driveways located along Brier Drive (referred to as Project Driveways No. 6, No. 7, No. 8, No. 9 and No. 10). Project Driveway No. 8 will be a full access driveway. Project Driveways No. 6, No. 7, No. 9 and No. 10 will be right-turn in/right-turn out only access driveways.








n:\4500\2214502 -- hardt and brier business park project, san bernardino\dwg\4502 f2-1.dwg LDP 16:17:16 03-13-2023 kopulsky

LINSCOTT  
LAW &  
GREENSPAN  
engineers



SOURCE: GOOGLE

KEY

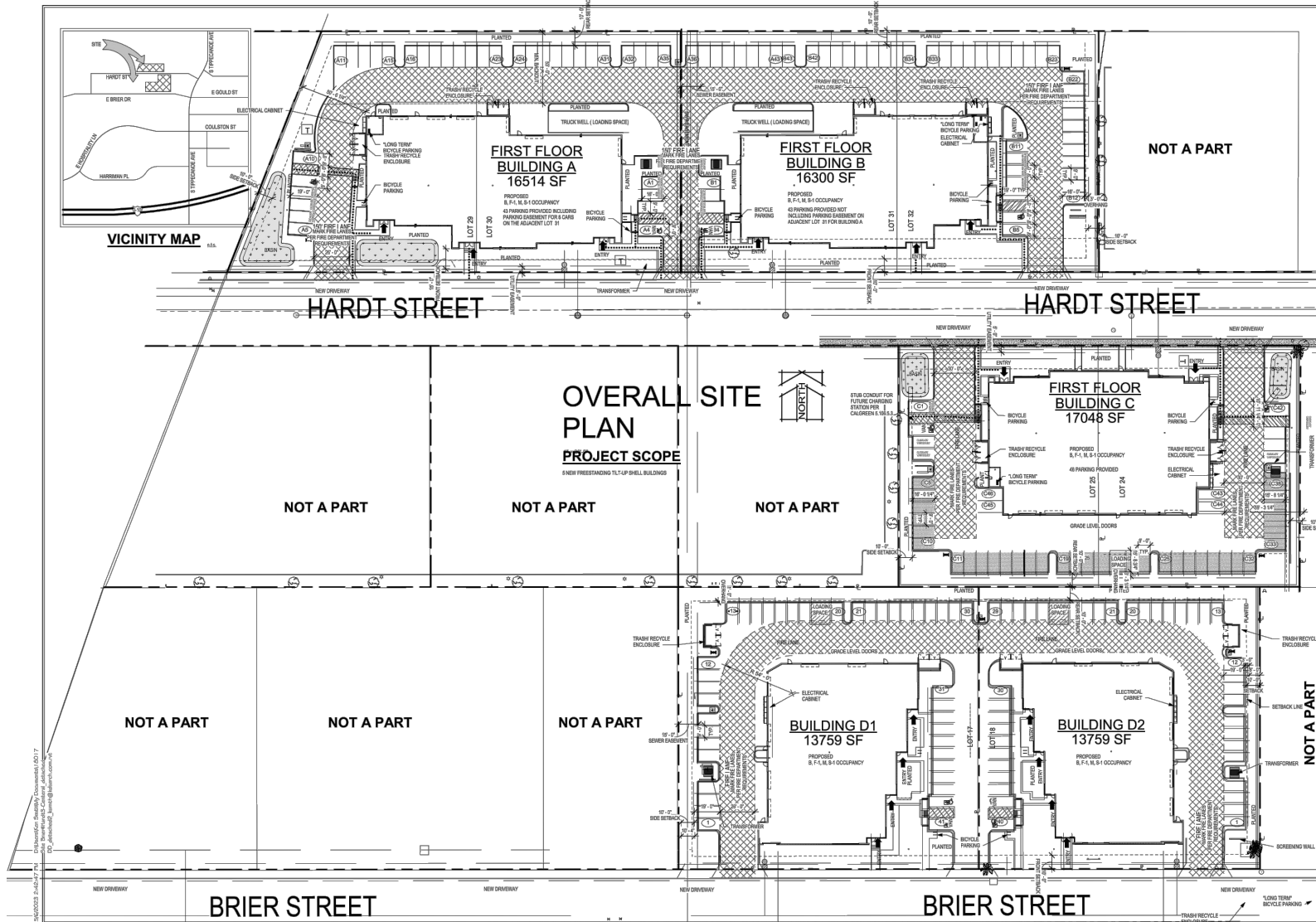
-  = STUDY INTERSECTION
-  = BUILDINGS A & B
-  = BUILDING C
-  = BUILDINGS D1 & D2
-  = BUILDING E

# FIGURE 2-1

## EXISTING SITE AERIAL

HARDT AND BRIER BUSINESS PARK PROJECT, SAN BERNARDINO





n:\4500\2214502 - hardt and brier business park project, san bernardino.dwg\_4502 f2-2.dwg LDP 14-35:42 05-10-2023 agular

SOURCE: KDS ARCHITECT & ASSOCIATES, INC.

## FIGURE 2-2

### PROPOSED SITE PLAN

HARDT AND BRIER BUSINESS PARK PROJECT, SAN BERNARDINO



## 3.0 ANALYSIS CONDITIONS AND METHODOLOGY

### 3.1 Existing Street Network

Regional access to the site is provided via the I-10 Freeway, which is located south of the project site. The principal local network of streets serving the project includes Tippecanoe Avenue, Hardt Street and Brier Drive. The following discussion provides a brief synopsis of these key area streets.

**Tippecanoe Avenue** is generally a six-lane, divided roadway north of the I-10 Freeway and generally a four-lane, divided roadway south of the I-10 Freeway, oriented in the north-south direction. On-street parking is not permitted along either side of the roadway within the vicinity of the Project site. The posted speed limit on Tippecanoe Avenue is 40 miles per hour (mph) north of the I-10 Freeway and 35 mph south of the I-10 Freeway. Tippecanoe Avenue is classified as a Major Arterial in the City of San Bernardino General Plan. Tippecanoe Avenue is classified as a Bicycle Route in the City of San Bernardino General Plan. A Class II Bike Lane currently exists on Tippecanoe Avenue between Harriman Place and the southerly City limits. Traffic signals control the study intersections of Tippecanoe Avenue at Brier Drive/Gould Street, Hospitality Lane/Coulston Street, Harriman Place/I-10 Westbound Ramps, and I-10 Eastbound Ramps.

**Hardt Street** is a two-lane, undivided roadway, oriented in the east-west direction that borders the project site to the north (i.e. Buildings A and B) and the south (i.e. Building C). On-street parking is generally not permitted along either side of the roadway within the vicinity of the Project site. Hardt Street is classified as a Local Street in the City of San Bernardino General Plan. No bike lanes currently exist or are planned along this roadway. A midblock crosswalk currently exists on Hardt Street between the easterly driveway for proposed Building B and the easterly driveway for proposed Building C. The operations of the midblock crosswalk will be unaffected by the proposed Project driveways on Hardt Street. The study intersection of Hardt Street at Tippecanoe Avenue is stop controlled (side-street stop).

**Brier Drive** is a four-lane, divided roadway, oriented in the east-west direction that borders the project site to the south (i.e. Buildings D1, D2 and E). On-street parking is generally not permitted along either side of the roadway within the vicinity of the Project site. Brier Drive is classified as a Secondary Arterial in the City of San Bernardino General Plan. No bike lanes currently exist or are planned along this roadway. A traffic signal controls the study intersection of Brier Drive at Tippecanoe Avenue.

#### Pedestrian Facilities

A sidewalk currently does not exist along the northern portion of Hardt Street, adjacent to the project frontage of Buildings A and B. A sidewalk currently exists along the southern portion of Hardt Street for a majority of the project frontage for Building C. A sidewalk currently does not exist along the northern portion of Brier Drive, adjacent to the project frontage of Buildings D and E. The proposed Project will provide sidewalks along the project frontages of each proposed building. Sidewalks currently exist along Tippecanoe Avenue in the vicinity of the project site.

*Figure 3-1* presents an inventory of the existing roadway conditions within the study area evaluated in this report. The number of travel lanes and intersection controls for the key area study intersections are identified. *Figure 3-2* shows the current City of San Bernardino General Plan Circulation Element.

### **3.2 Existing Traffic Volumes**

Five (5) key study intersections have been identified as the locations at which to evaluate existing and future traffic operating conditions. Some portion of potential project-related traffic will pass through each of these intersections, and their analysis will reveal the expected relative impacts of the project. These key intersections were selected for evaluation based on coordination with City of San Bernardino Public Works Department staff.

Existing AM peak hour and PM peak hour traffic volumes for the five (5) key study intersections evaluated in this report were conducted by Counts Unlimited in January 2022. *Figures 3-3* and *3-4* illustrate the existing AM and PM peak hour traffic volumes at the five (5) key study intersections evaluated in this report, respectively. *Appendix B* contains the detailed peak hour traffic count sheets for the key intersections evaluated in this report.

### **3.3 Level of Service (LOS) Analysis Methodologies**

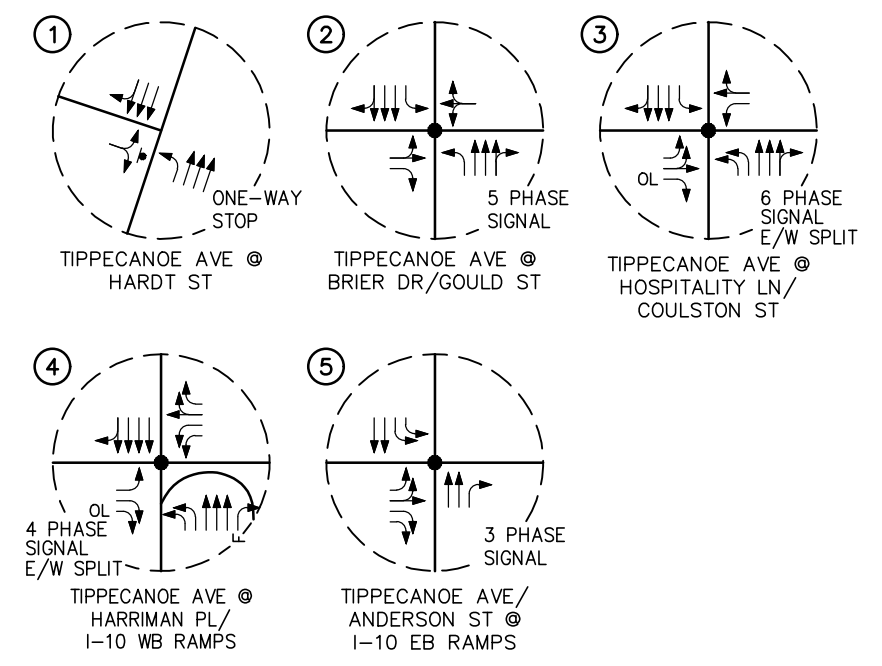
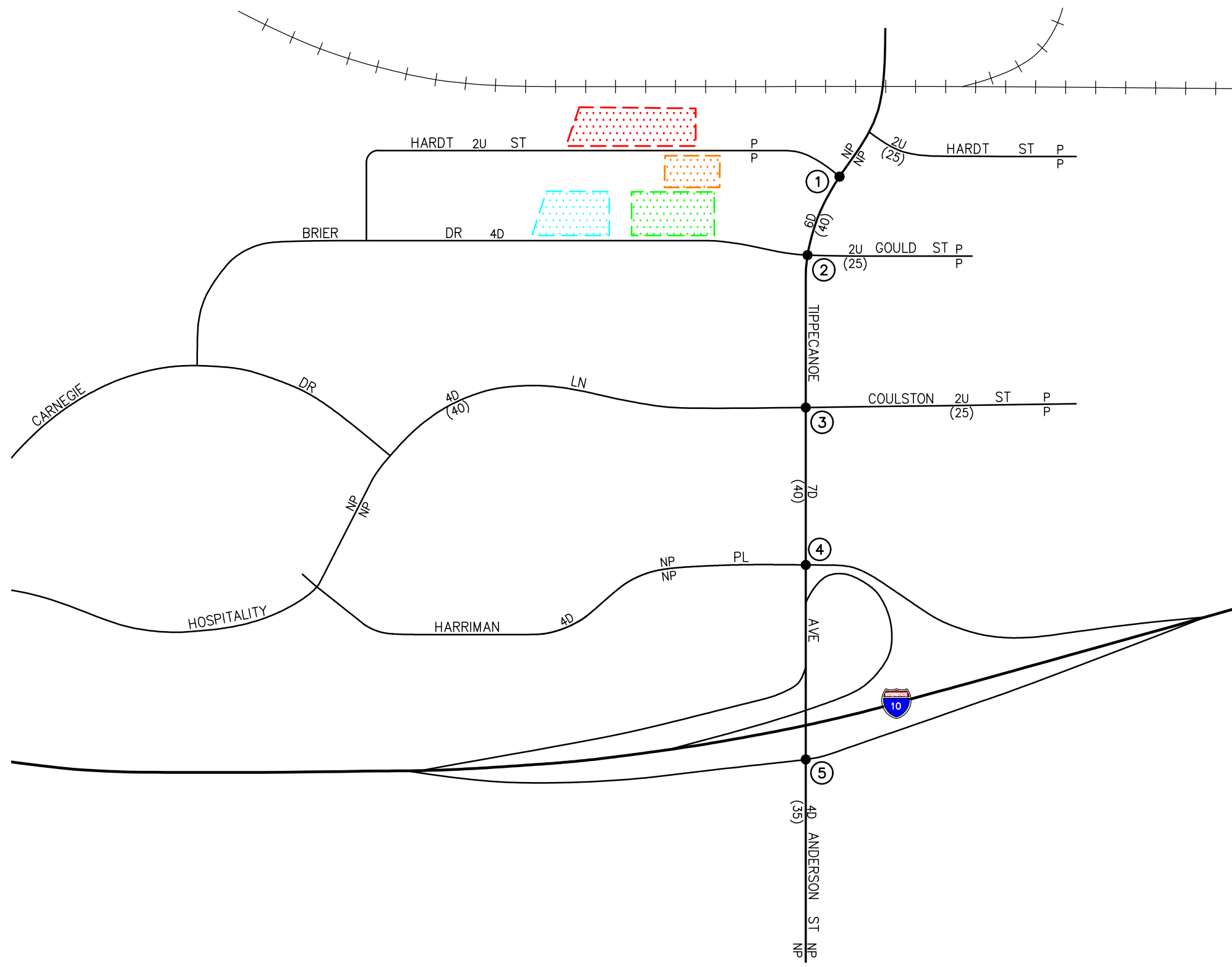
AM and PM peak hour operating conditions for the key study intersections were evaluated using the methodology outlined in *Chapter 19 of the Highway Capacity Manual 7 (HCM 7)* for signalized intersections, the methodology outlined in *Chapter 20 of the HCM 7* for two-way stop-controlled intersections and the methodology outlined in *Chapter 21 of the HCM 7* for all-way stop-controlled intersections.

#### **3.3.1 Highway Capacity Manual 7 (HCM 7) Method of Analysis (Signalized Intersections)**

Based on the HCM operations method of analysis, level of service for signalized intersections and approaches is defined in terms of control delay, which is a measure of the increase in travel time due to traffic signal control, driver discomfort and fuel consumption. Control delay includes the delay associated with vehicles slowing in advance of an intersection, the time spent stopped on an intersection approach, the time spent as vehicles move up in the queue and the time needed for vehicles to accelerate to their desired speed. LOS criteria for traffic signals are stated in terms of the control delay in seconds per vehicle. The LOS thresholds established for the automobile mode at a signalized intersection are shown in *Table 3-1*.

#### **3.3.2 Highway Capacity Manual 7 (HCM 7) Method of Analysis (Unsignalized Intersections)**

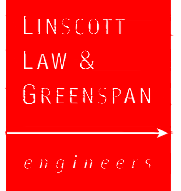
The HCM unsignalized methodology for stop-controlled intersections was utilized for the analysis of the unsignalized intersections. LOS criteria for unsignalized intersections differ from LOS criteria for signalized intersections as signalized intersections are designed for heavier traffic and therefore a greater delay. Unsignalized intersections are also associated with more uncertainty for users, as delays are less predictable, which can reduce users' delay tolerance.



n:\4500\2214502 - hardt and brier business park project, san bernardino\dwg\4502 f3-1.dwg LDP 16:18:28 03-13-2023 kopulsky

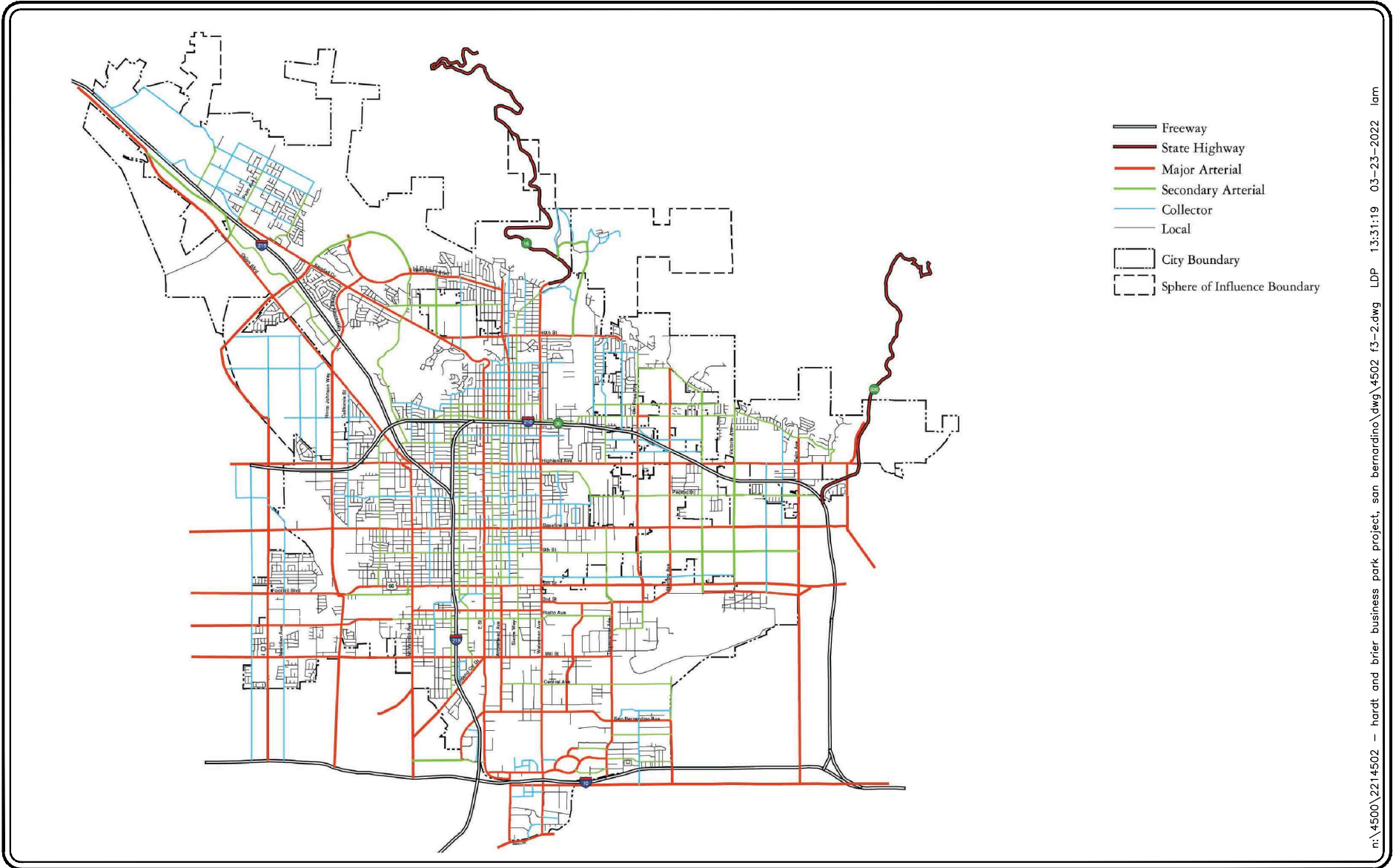
**KEY**

- ← = APPROACH LANE ASSIGNMENT
- = TRAFFIC SIGNAL, ▼ = STOP SIGN
- P = PARKING, NP = NO PARKING
- U = UNDIVIDED, D = DIVIDED
- 2 = NUMBER OF TRAVEL LANES
- (XX) = POSTED SPEED LIMIT (MPH)
- F = FREE-RIGHT
- OL = OVERLAP
- [Red Dotted Box] = BUILDINGS A & B
- [Orange Dotted Box] = BUILDING C
- [Green Dotted Box] = BUILDINGS D1 & D2
- [Blue Dotted Box] = BUILDING E
- ++ = RAILROAD TRACKS



**FIGURE 3-1**

**EXISTING ROADWAY CONDITIONS AND INTERSECTION CONTROLS**  
HARDT AND BRIER BUSINESS PARK PROJECT, SAN BERNARDINO



n:\4500\2214502 - hardt and brier business park project, san bernardino.dwg\4502 f3-2.dwg LDP 13:31:19 03-23-2022 lam

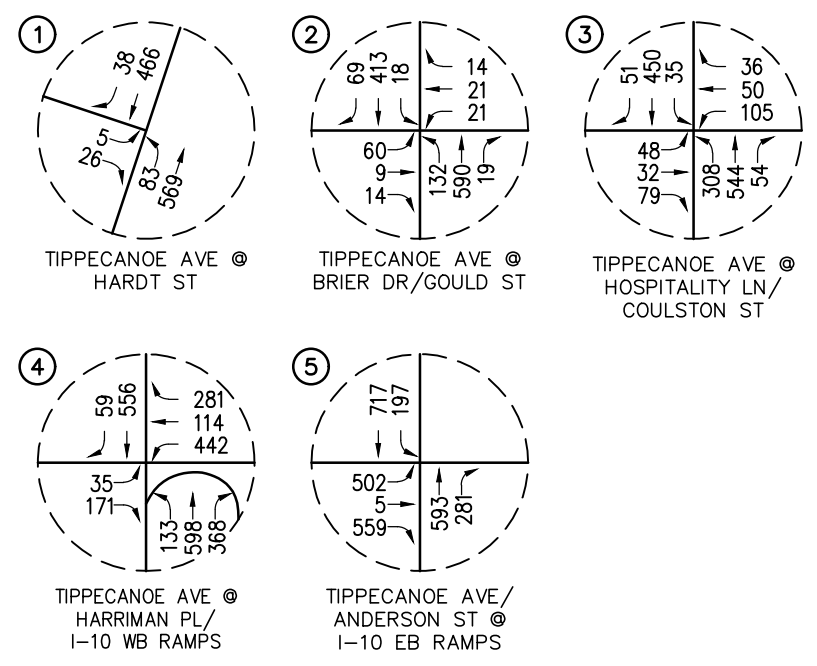
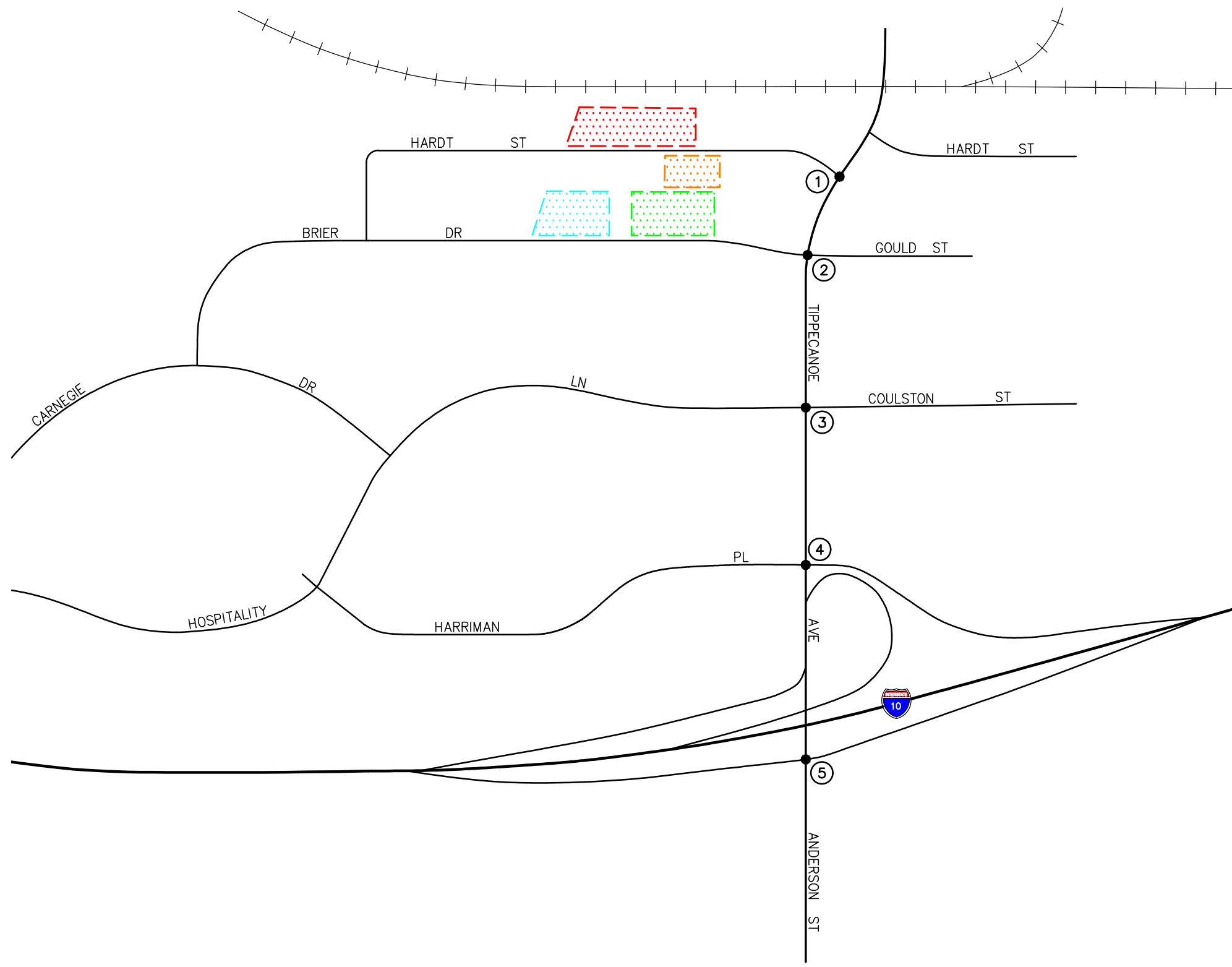
SOURCE: CITY OF SAN BERNARDINO

**FIGURE 3-2**

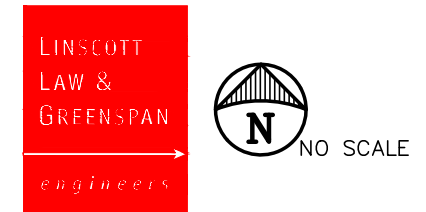
**LINSCOTT  
LAW &  
GREENSPAN**  
engineers

NO SCALE

**CITY OF SAN BERNARDINO GENERAL PLAN CIRCULATION ELEMENT**  
HARDT AND BRIER BUSINESS PARK PROJECT, SAN BERNARDINO



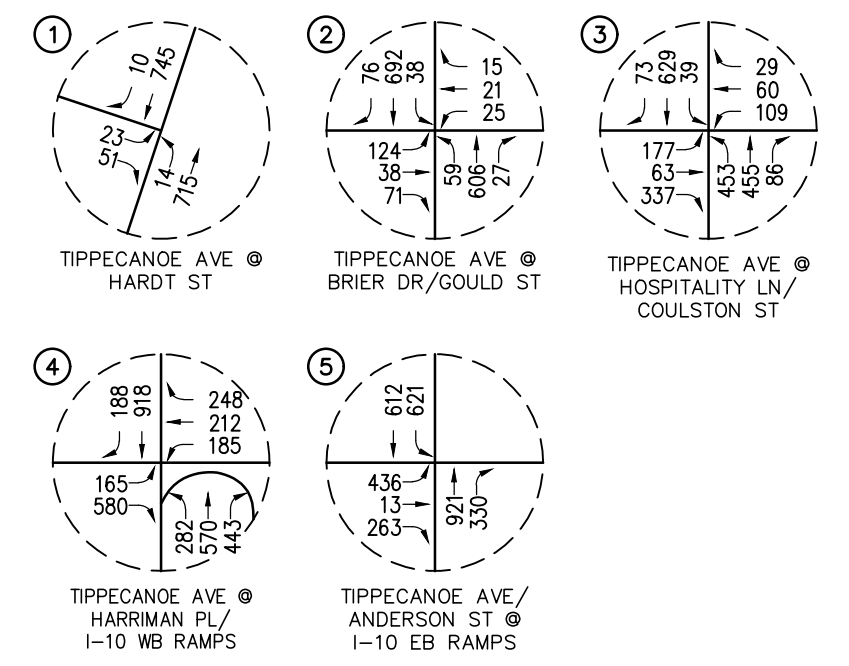
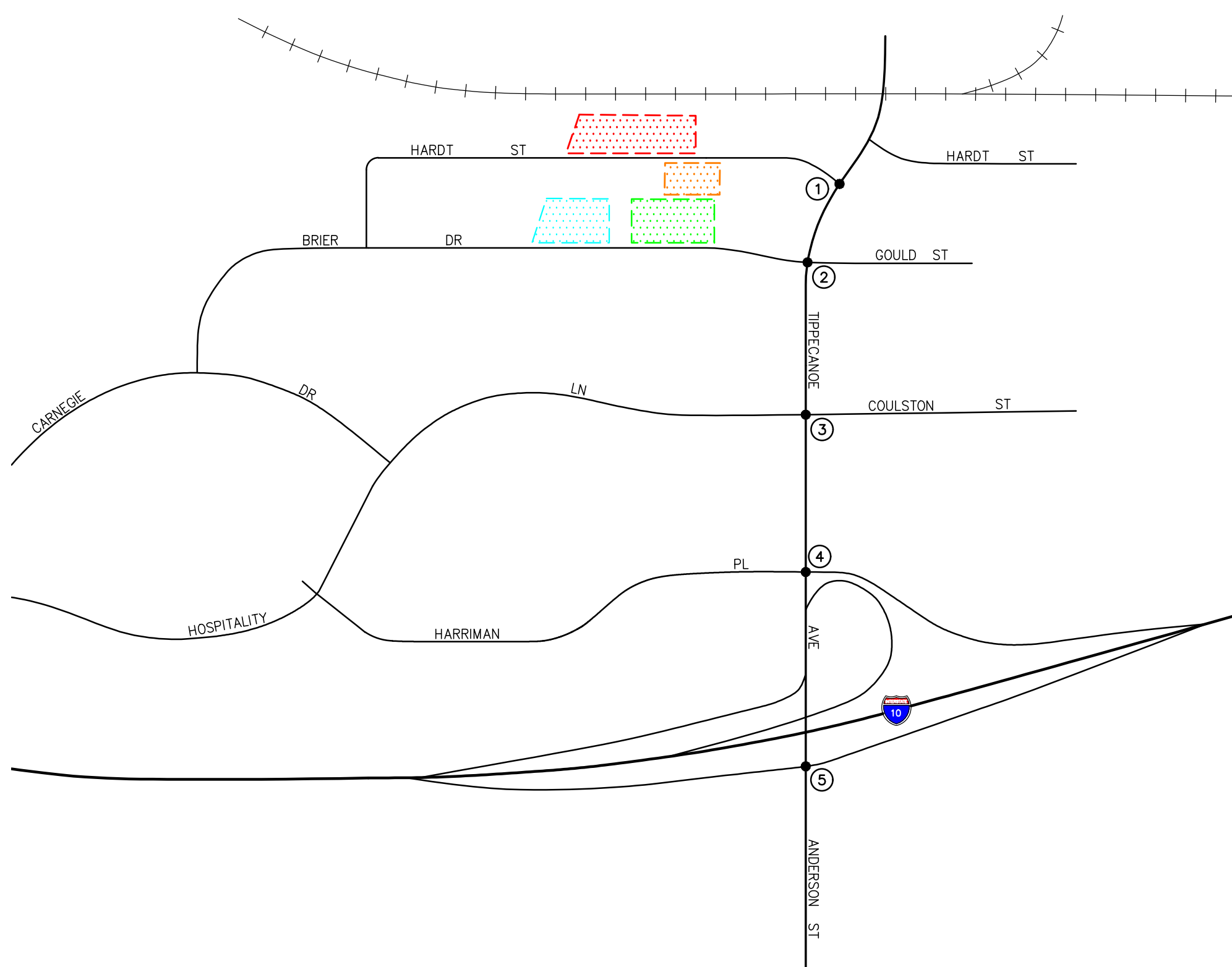
n:\4500\2214502 - hardt and brier business park project, san bernardino\dwg\4502 f3-3.dwg LDP 16:19:03 03-13-2023 kopulsky



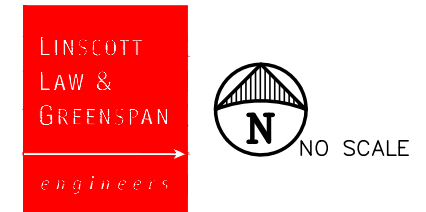
- KEY**
- # = STUDY INTERSECTION
  - + + = RAILROAD TRACKS
  - [Red Dotted Box] = BUILDINGS A & B
  - [Orange Dotted Box] = BUILDING C
  - [Green Dotted Box] = BUILDINGS D1 & D2
  - [Cyan Dotted Box] = BUILDING E

**FIGURE 3-3**

**EXISTING AM PEAK HOUR TRAFFIC VOLUMES**  
HARDT AND BRIER BUSINESS PARK PROJECT, SAN BERNARDINO



n:\4500\2214502 - hardt and brier business park project, san bernardino\dwg\4502 f3-4.dwg LDP 16:19:33 03-13-2023 kopulsky



- KEY**
- # = STUDY INTERSECTION
  - + + = RAILROAD TRACKS
  - [Red Hatched Box] = BUILDINGS A & B
  - [Orange Hatched Box] = BUILDING C
  - [Green Hatched Box] = BUILDINGS D1 & D2
  - [Cyan Hatched Box] = BUILDING E

**FIGURE 3-4**

**EXISTING PM PEAK HOUR TRAFFIC VOLUMES**  
HARDT AND BRIER BUSINESS PARK PROJECT, SAN BERNARDINO

### 3.3.2.1 Two-Way Stop-Controlled Intersections

Two-way stop-controlled intersections are comprised of a major street, which is uncontrolled and a minor street, which is controlled by stop signs. Level of service for a two-way stop-controlled intersection is determined by the computed or measured control delay. The control delay by movement, by approach and for the intersection as a whole is estimated by the computed capacity for each movement. LOS is determined for each minor-street movement (or shared movement) as well as major-street left turns. The worst side street approach delay is reported. LOS is not defined for the intersection as a whole or for major-street approaches, as it is assumed that major-street through vehicles experience zero delay. The HCM control delay value ranges for two-way stop-controlled intersections are shown in *Table 3-2*.

### 3.3.2.2 All-Way Stop-Controlled Intersections

All-way stop-controlled intersections require every vehicle to stop at the intersection before proceeding. Because each driver must stop, the decision to proceed into the intersection is a function of traffic conditions on the other approaches. The time between subsequent vehicle departures depends on the degree of conflict that results between the vehicles and vehicles on the other approaches. This methodology determines the control delay for each lane on the approach, computes a weighted average for the whole approach and computes a weighted average for the intersection as a whole. Level of service (LOS) at the approach and intersection levels is based solely on control delay. The HCM control delay value ranges for all-way stop-controlled intersections are shown in *Table 3-2*.

## 3.4 Impact Criteria and Thresholds

### 3.4.1 City of San Bernardino

According to the *City of San Bernardino Traffic Impact Analysis Guidelines*, dated August 2020, LOS D is the minimum acceptable condition that should be maintained during the peak commute hours. Therefore, any intersection operating at LOS E or LOS F is considered deficient/unsatisfactory.

- For signalized intersections, traffic impacts are to be considered “significant” when any of the following changes in the volume-to-capacity (V/C) ratios occur between the “without project” and the “with project” conditions:

<u>LOS Without Project</u>	<u>V/C Difference</u>
C	> 0.0400
D	> 0.0200
E, F	> 0.0100

Given that the City of San Bernardino does not have specific impact criteria for unsignalized intersections, this report defines the following impact criteria for unsignalized intersections.



- An unsignalized intersection impact is considered to be significant if the project causes an intersection at LOS D or better to degrade to LOS E or LOS F, and the traffic signal warrant analysis determines that a traffic signal is justified.

The aforementioned criteria will be applied to key study intersections #1, #2, #3 and #4, which are located in the City of San Bernardino.

### **3.4.2 City of Loma Linda**

The City of Loma Linda utilizes the County of San Bernardino's guidelines for level of service analyses. The proposed Project is located within the Valley region of San Bernardino County and therefore the following criteria as stated in the *San Bernardino County Transportation Impact Study Guidelines*, dated July 2019 has been utilized to evaluate the impacts at the one (1) key study intersection located within the City of Loma Linda (i.e. key study intersection #5).

#### Signalized Intersections

- Any signalized study intersection in the Valley or Mountain regions that is operating at an acceptable LOS D or better without project traffic in which the addition of project traffic causes the intersection to degrade to an LOS E or F shall identify improvements to improve operations to LOS D or better.
- Any signalized study intersection in the Valley or Mountain regions that is operating at LOS E or F without project traffic where the project increases delay by 5.0 or more seconds shall identify improvements to offset the increase in delay.

#### Unsignalized Intersections

Consistent with the acceptable LOS for the Desert, Valley, and Mountain regions as described in the current General Plan, the County should consider the following unsignalized intersection criteria when identifying operational deficiencies:

An operational improvement would be required if the study determines that either section a) or both sections b) and c) occur:

a) The addition of project related traffic causes the intersection to degrade from an LOS D or better to a LOS E or worse in the Valley and Mountain regions or from an LOS C or better to an LOS D or worse in the Desert region.

OR

b) The project adds 5.0 seconds or more of delay to an intersection that is already projected to operate without project traffic at an LOS E or F in the Valley and Mountain regions or at an LOS D, E, or F in the Desert region (per Section 10.5.2 b))

AND

c) One or both of the following conditions are met:

- 1) The project adds ten (10) or more trips to any minor street approach
- 2) The intersection meets the peak hour traffic signal warrant after the addition of project traffic (per Section 10.5.2 c)).

If the conditions above are satisfied, improvements should be identified that achieve the following:

- In the Valley and Mountain regions, improvements should be identified that would achieve LOS D or better for case a) above or to pre-project LOS and delay for case b) above.

**TABLE 3-1  
LEVEL OF SERVICE CRITERIA FOR SIGNALIZED INTERSECTIONS (HCM 7 METHODOLOGY)<sup>2</sup>**

<b>Level of Service (LOS)</b>	<b>Control Delay Per Vehicle (seconds/vehicle)</b>	<b>Level of Service Description</b>
A	$\leq 10.0$	This level of service occurs when progression is extremely favorable and most vehicles arrive during the green phase. Most vehicles do not stop at all. Short cycle lengths may also contribute to low delay.
B	$> 10.0$ and $\leq 20.0$	This level generally occurs with good progression, short cycle lengths, or both. More vehicles stop than with LOS A, causing higher levels of average delay.
C	$> 20.0$ and $\leq 35.0$	Average traffic delays. These higher delays may result from fair progression, longer cycle lengths, or both. Individual cycle failures may begin to appear at this level. The number of vehicles stopping is significant at this level, though many still pass through the intersection without stopping.
D	$> 35.0$ and $\leq 55.0$	Long traffic delays At level D, the influence of congestion becomes more noticeable. Longer delays may result from some combination of unfavorable progression, long cycle lengths, or high $v/c$ ratios. Many vehicles stop and the proportion of vehicles not stopping declines. Individual cycle failures are noticeable.
E	$> 55.0$ and $\leq 80.0$	Very long traffic delays This level is considered by many agencies to be the limit of acceptable delay. These high delay values generally indicate poor progression, long cycle lengths and high $v/c$ ratios. Individual cycle failures are frequent occurrences.
F	$\geq 80.0$	Severe congestion This level, considered to be unacceptable to most drivers, often occurs with over saturation, that is, when arrival flow rates exceed the capacity of the intersection. It may also occur at high $v/c$ ratios below 1.0 with many individual cycle failures. Poor progression and long cycle lengths may also be major contributing factors to such delay levels.

<sup>2</sup> Source: *Highway Capacity Manual 7*, Chapter 19: Signalized Intersections.

**TABLE 3-2**

**LEVEL OF SERVICE CRITERIA FOR UNSIGNALIZED INTERSECTIONS (HCM 7 METHODOLOGY)<sup>3,4</sup>**

<b>Level of Service (LOS)</b>	<b>Highway Capacity Manual (HCM) Delay Per Vehicle (seconds/vehicle)</b>	<b>Level of Service Description</b>
A	≤ 10.0	Little or no delay
B	> 10.0 and ≤ 15.0	Short traffic delays
C	> 15.0 and ≤ 25.0	Average traffic delays
D	> 25.0 and ≤ 35.0	Long traffic delays
E	> 35.0 and ≤ 50.0	Very long traffic delays
F	> 50.0	Severe congestion

<sup>3</sup> Source: *Highway Capacity Manual 7*, Chapter 20: Two-Way Stop-Controlled Intersections. The LOS criteria apply to each lane on a given approach and to each approach on the minor street. LOS is not calculated for major-street approaches or for the intersection as a whole.

<sup>4</sup> Source: *Highway Capacity Manual 7*, Chapter 21: All-Way Stop-Controlled Intersections. For approaches and intersection-wide assessment, LOS is defined solely by control delay.

## 4.0 TRAFFIC FORECASTING METHODOLOGY

In order to estimate the traffic impact characteristics of the Project, a multi-step process has been utilized. The first step is traffic generation, which estimates the total arriving and departing traffic on a peak hour and daily basis. The traffic generation potential is forecast by applying the appropriate vehicle trip generation equations and/or rates to the Project development tabulation.

The second step of the forecasting process is traffic distribution, which identifies the origins and destinations of inbound and outbound Project traffic. These origins and destinations are typically based on demographics and existing/expected future travel patterns in the study area.

The third step is traffic assignment, which involves the allocation of Project traffic to study area streets and intersections. Traffic assignment is typically based on minimization of travel time, which may or may not involve the shortest route, depending on prevailing operating conditions and travel speeds.

Traffic distribution patterns are indicated by general percentage orientation, while traffic assignment allocates specific volume forecasts to individual roadway segments and intersection turning movements throughout the study area.

With the forecasting process complete and Project traffic assignments developed, the impact of the Project is isolated by comparing operational (LOS) conditions at selected key intersections using expected future traffic volumes with and without forecast Project traffic. If necessary, the need for site-specific and/or cumulative local area improvements can then be evaluated.

## 5.0 PROJECT TRAFFIC CHARACTERISTICS

### 5.1 Project Trip Generation Forecast

Traffic generation is expressed in vehicle trip ends, defined as one-way vehicular movements, either entering or exiting the generating land use. Generation equations and/or rates used in the traffic forecasting procedure are found in the 11<sup>th</sup> Edition of *Trip Generation*, published by the Institute of Transportation Engineers (ITE) [Washington D.C., 2021].

*Table 5-1* summarizes the trip generation rates used in forecasting the vehicular trips generated by the proposed Project and presents the forecast daily and peak hour project traffic volumes for a “typical” weekday. As shown in the upper portion of *Table 5-1*, the trip generation potential of the proposed Project has been estimated using ITE Land Use 770: Business Park trip rates.

A review of the bottom of *Table 5-1* indicates that the proposed Project is forecast to generate approximately 1,350 daily trips, with 146 trips (124 inbound, 22 outbound) produced in the AM peak hour and 132 trips (35 inbound, 97 outbound) produced in the PM peak hour on a “typical” weekday. The potential impact of these trips are assessed in the traffic study. It should be noted that the Project trip generation was submitted to City staff for their review and approval prior to proceeding with further analyses.

### 5.2 Project Trip Distribution and Assignment

The Project directional trip distribution patterns are presented in *Figures 5-1, 5-2, 5-3* and *5-4*. *Figure 5-1* presents the project traffic distribution pattern for Buildings A and B. *Figure 5-2* presents the project traffic distribution pattern for Building C. *Figure 5-3* presents the project traffic distribution pattern for Buildings D1 and D2. *Figure 5-4* presents the project traffic distribution pattern for Building E. Project traffic volumes both entering and exiting the site have been distributed and assigned to the adjacent street system based on the following considerations:

- the site's proximity to major traffic carriers (i.e. Tippecanoe Avenue, etc.),
- expected localized traffic flow patterns based on adjacent street channelization and presence of traffic signals; and
- ingress/egress availability at the Project site.

It should be noted that the Project trip distribution patterns were submitted to City staff for their review and approval prior to proceeding with further analyses.

The anticipated AM and PM peak hour Project traffic volumes at the five (5) key study intersections and project driveways are presented in *Figures 5-5* and *5-6*, respectively. The traffic volume assignments presented in the above-mentioned figures reflect the Project trip distribution characteristics shown in *Figures 5-1, 5-2, 5-3* and *5-4* and the Project trip generation forecast presented in *Table 5-1*.

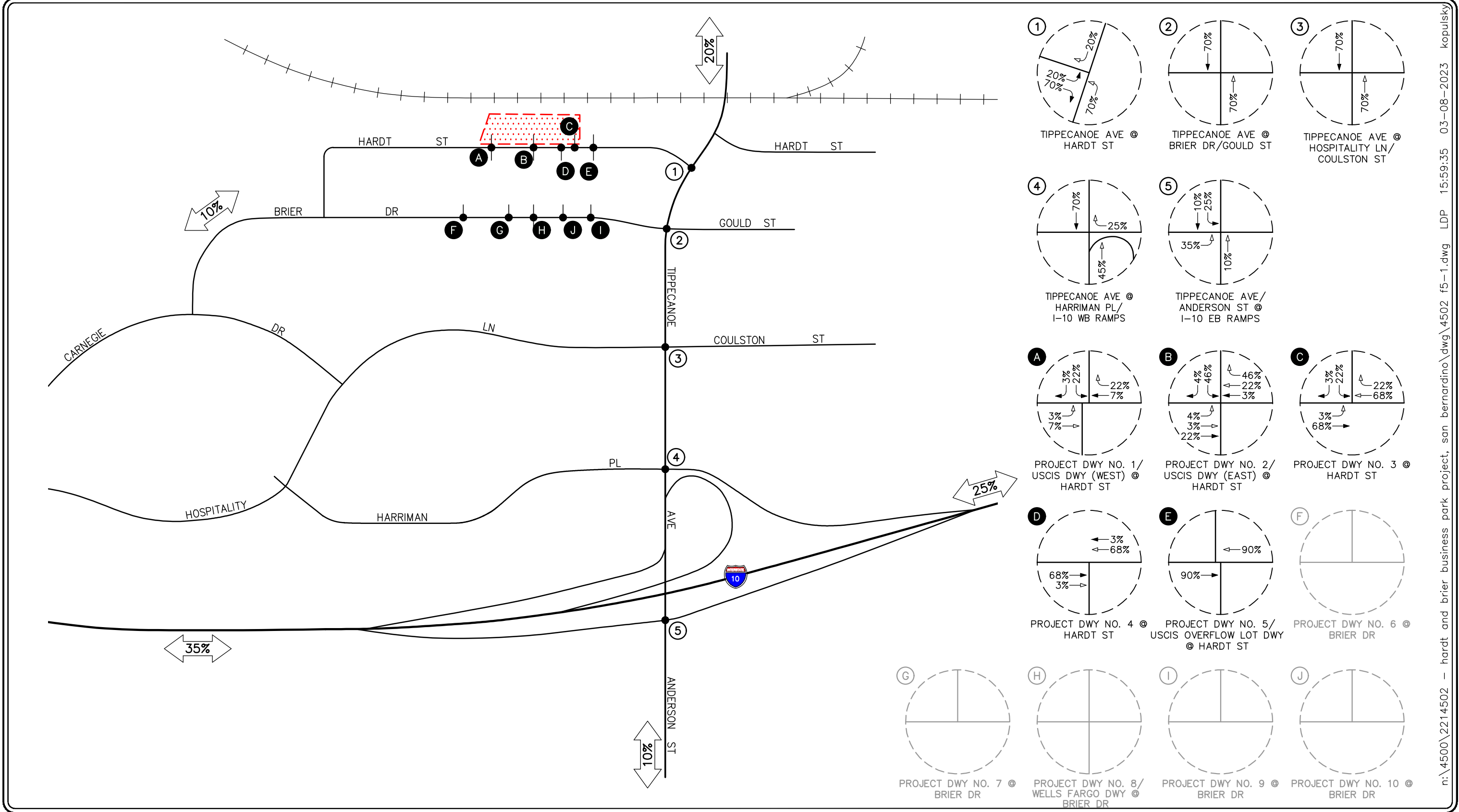
**TABLE 5-1  
PROJECT TRAFFIC GENERATION RATES AND FORECAST<sup>5</sup>**

ITE Land Use Code / Project Description	Daily 2-Way	AM Peak Hour			PM Peak Hour		
		Enter	Exit	Total	Enter	Exit	Total
<b><u>Generation Rates:</u></b>							
▪ 770: Business Park (TE/TSF)	12.44	85%	15%	1.35	26%	74%	1.22
<b><u>Proposed Project Generation Forecast:</u></b>							
▪ Business Park –Buildings A & B (35.500 TSF)	442	41	7	48	11	32	43
▪ Business Park –Building C (18.400 TSF)	229	21	4	25	6	16	22
▪ Business Park –Buildings D1 and D2 (27.600 TSF)	343	31	6	37	9	25	34
▪ Business Park –Building E (27.000 TSF)	336	31	5	36	9	24	33
<b>Total Proposed Project Trip Generation Forecast</b>	<b>1,350</b>	<b>124</b>	<b>22</b>	<b>146</b>	<b>35</b>	<b>97</b>	<b>132</b>

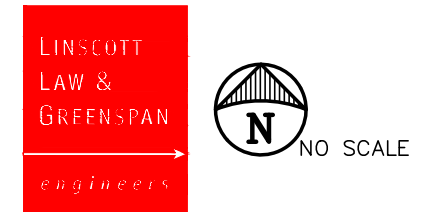
Note:

- TE/TSF = Trip End per Thousand Square Feet

<sup>5</sup> Source: *Trip Generation, 11th Edition*, Institute of Transportation Engineers, (ITE) [Washington, D.C. (2021)].



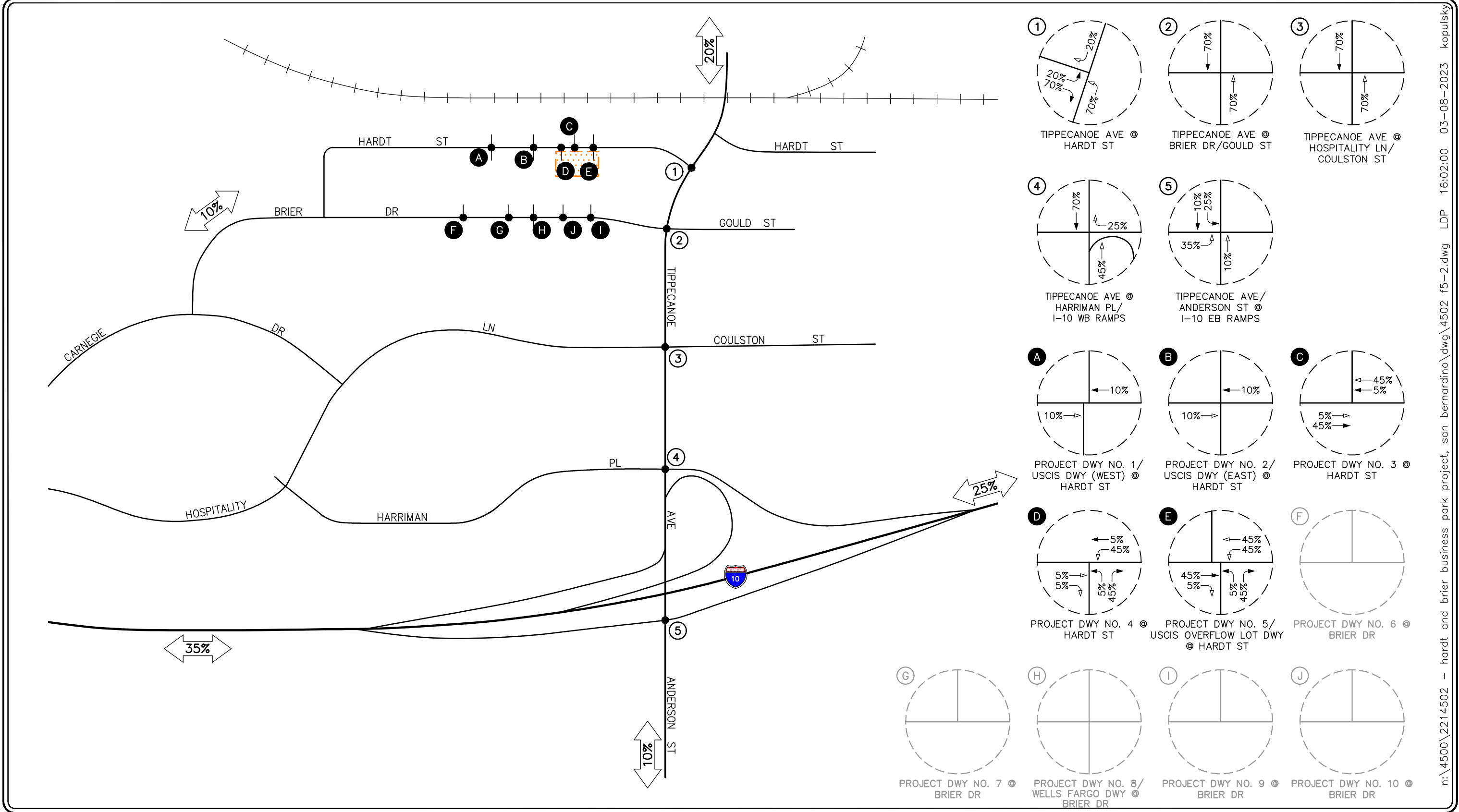
n:\4500\2214502 - hardt and brier business park project, san bernardino\dwg\4502 f5-1.dwg LDP 15:59:35 03-08-2023 kopulsky



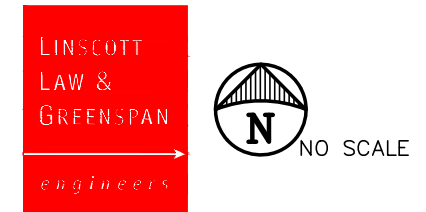
- KEY**
- # = STUDY INTERSECTION
  - ++ = RAILROAD TRACKS
  - ↖ = INBOUND PERCENTAGE
  - ↗ = OUTBOUND PERCENTAGE
  - [Red Dotted Box] = BUILDINGS A & B

**FIGURE 5-1**  
**PROJECT TRAFFIC DISTRIBUTION PATTERN (BUILDINGS A & B)**  
 HARDT AND BRIER BUSINESS PARK PROJECT, SAN BERNARDINO





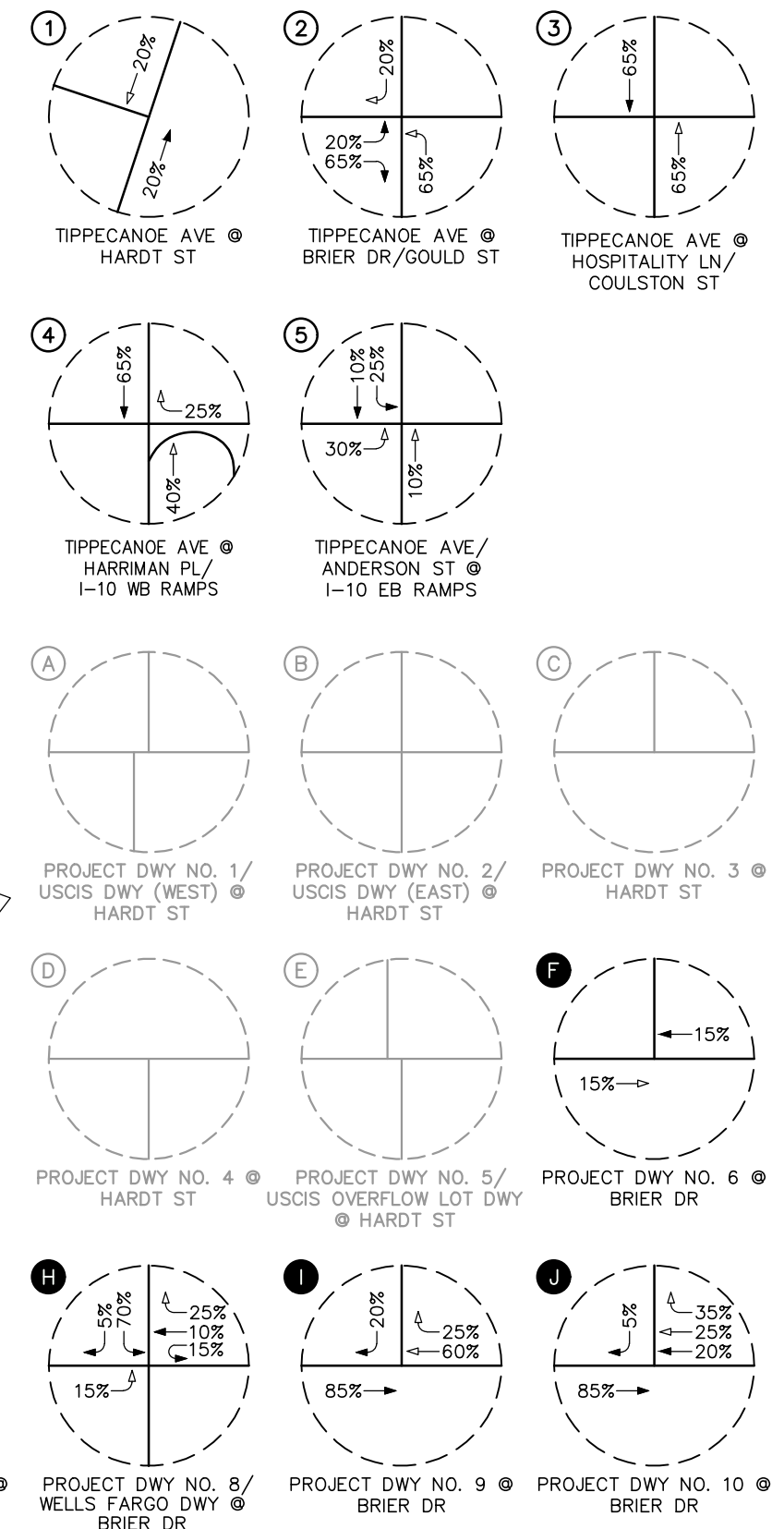
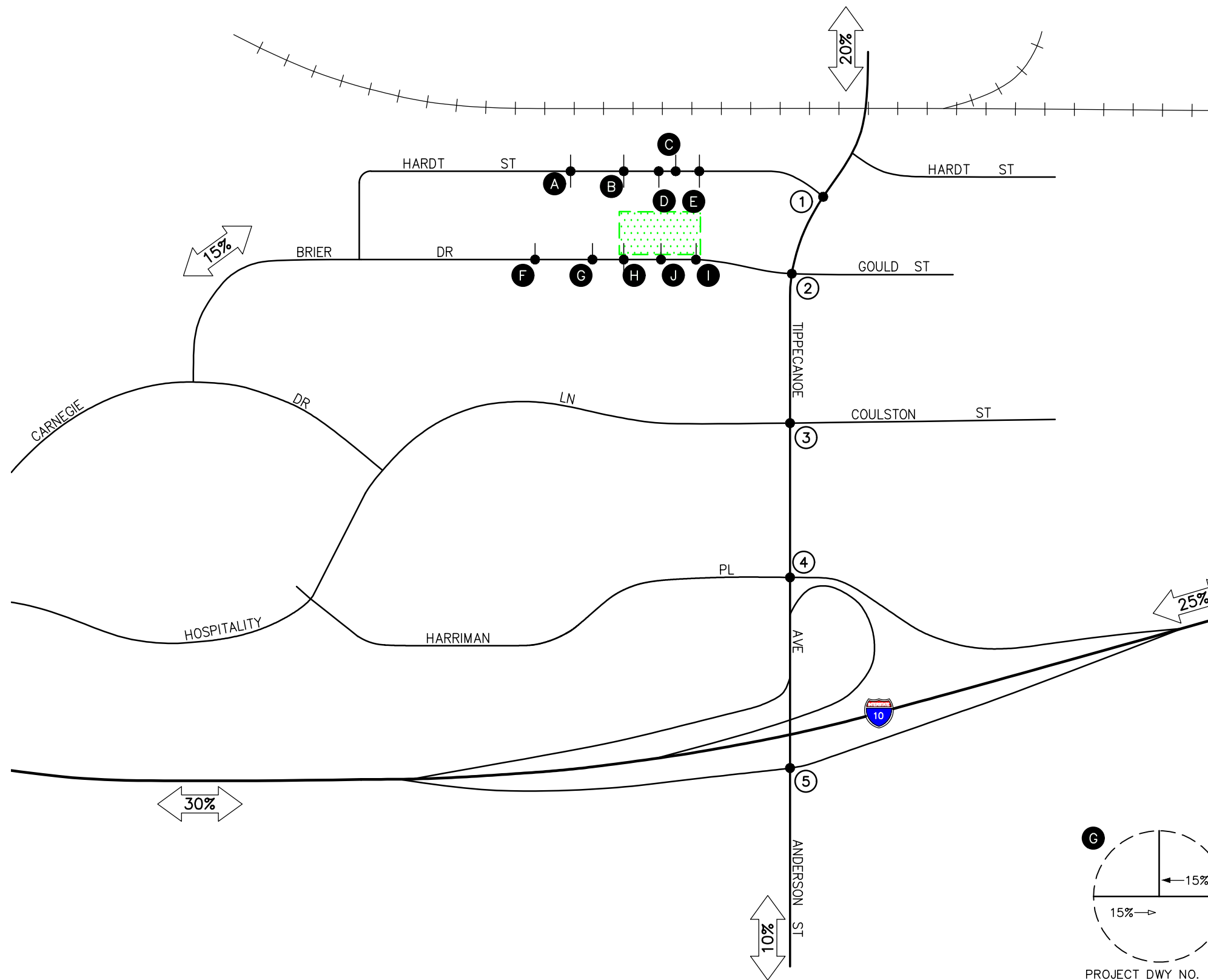
n:\4500\2214502 - hardt and brier business park project, san bernardino\dwg\4502 f5-2.dwg LDP 16:02:00 03-08-2023 kopulsky



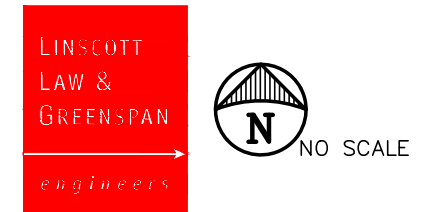
**KEY**

- # = STUDY INTERSECTION
- ++ = RAILROAD TRACKS
- ↔ = INBOUND PERCENTAGE
- ← = OUTBOUND PERCENTAGE
- ▨ = BUILDING C

**FIGURE 5-2**  
**PROJECT TRAFFIC DISTRIBUTION PATTERN (BUILDING C)**  
 HARDT AND BRIER BUSINESS PARK PROJECT, SAN BERNARDINO

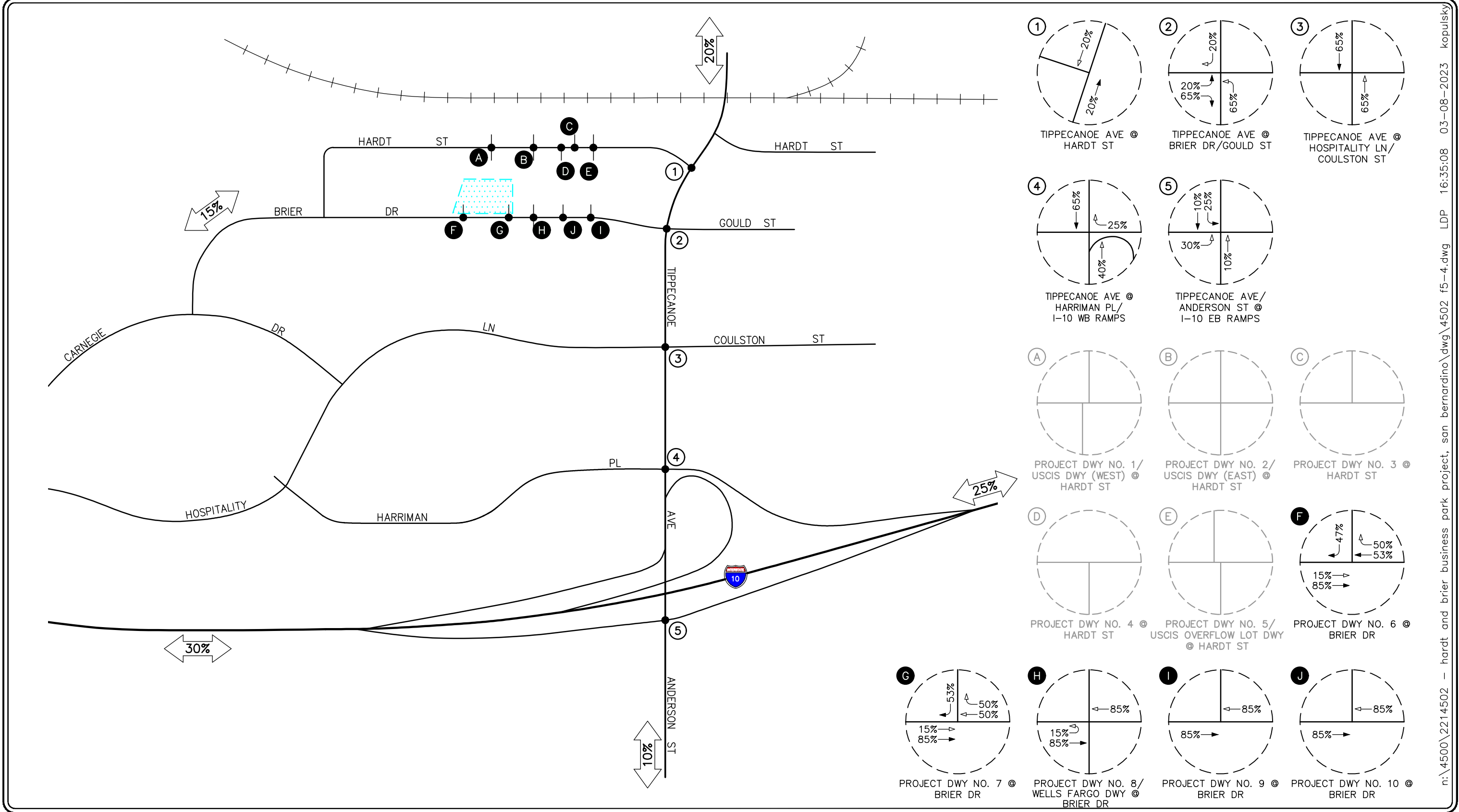


n:\4500\2214502 - hardt and brier business park project, san bernardino\dwg\4502 f5-3.dwg LDP 16:31:45 03-08-2023 kopulsky

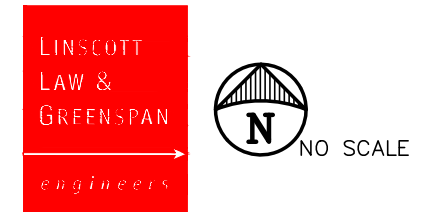


- KEY**
- # = STUDY INTERSECTION
  - ++ = RAILROAD TRACKS
  - ↔ = INBOUND PERCENTAGE
  - ← = OUTBOUND PERCENTAGE
  - [Hatched Box] = BUILDINGS D1 & D2

**FIGURE 5-3**  
**PROJECT TRAFFIC DISTRIBUTION PATTERN (BUILDINGS D1 AND D2)**  
 HARDT AND BRIER BUSINESS PARK PROJECT, SAN BERNARDINO



n:\4500\2214502 - hardt and brier business park project, san bernardino\dwg\4502 f5-4.dwg LDP 16:35:08 03-08-2023 kopulsky

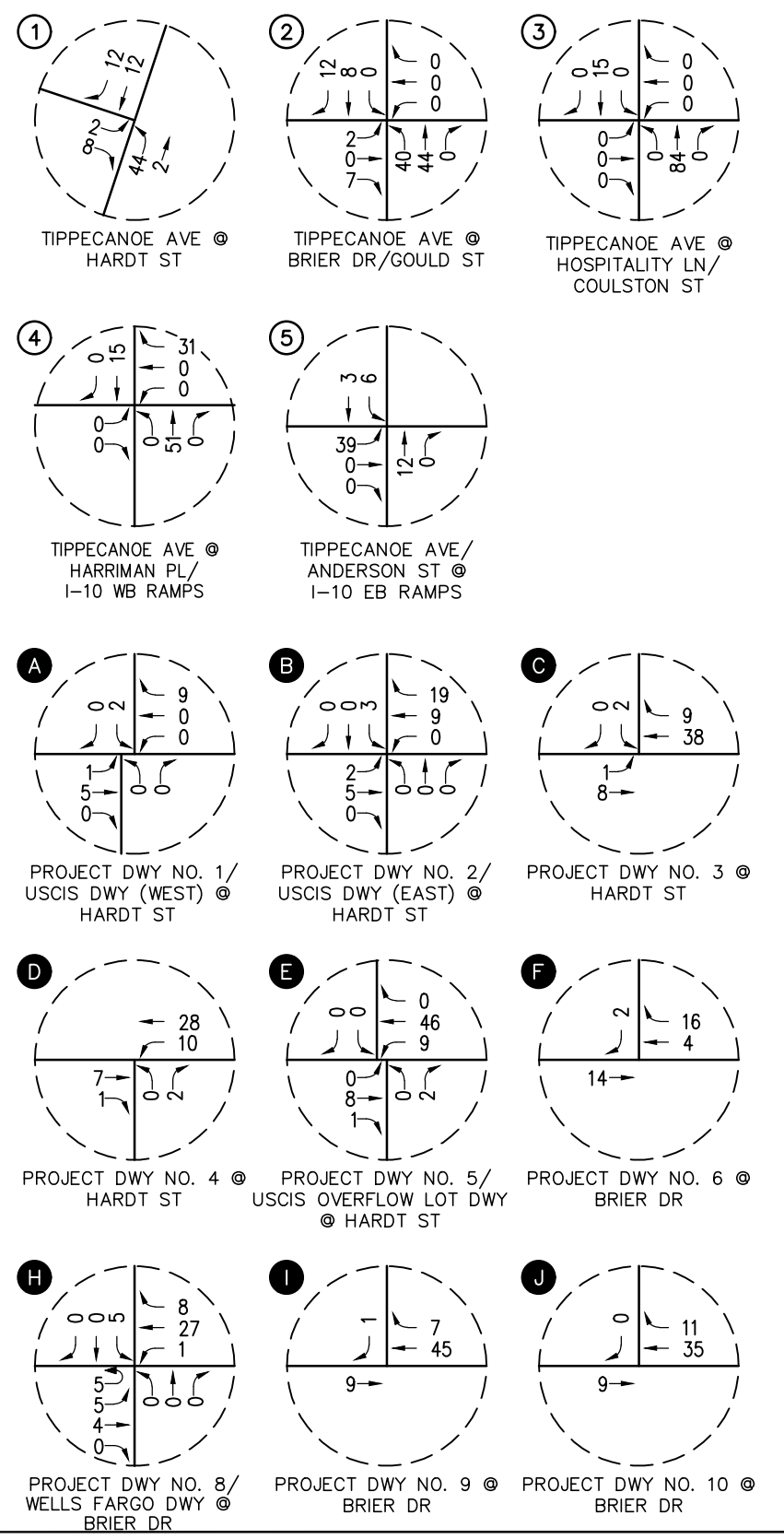
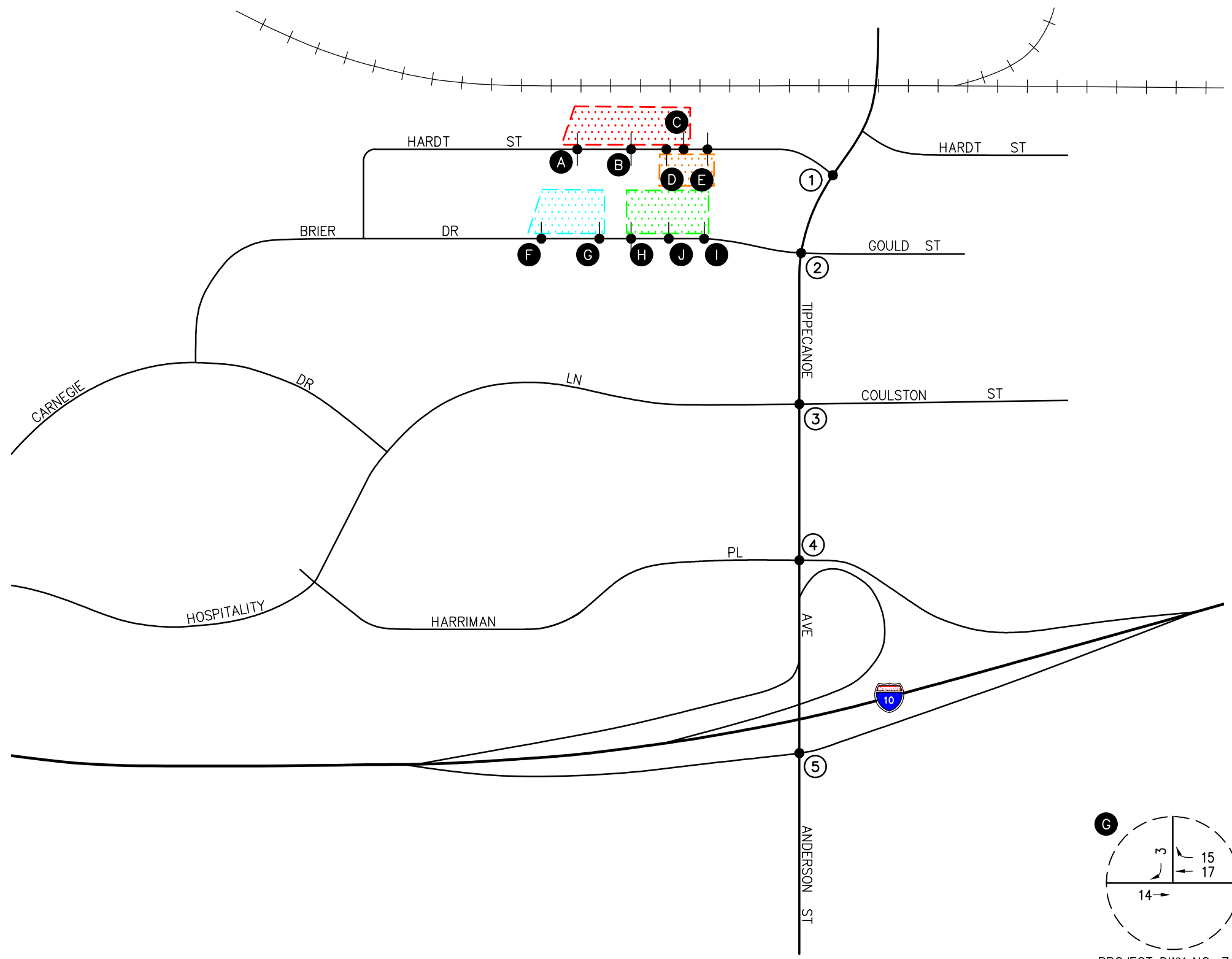


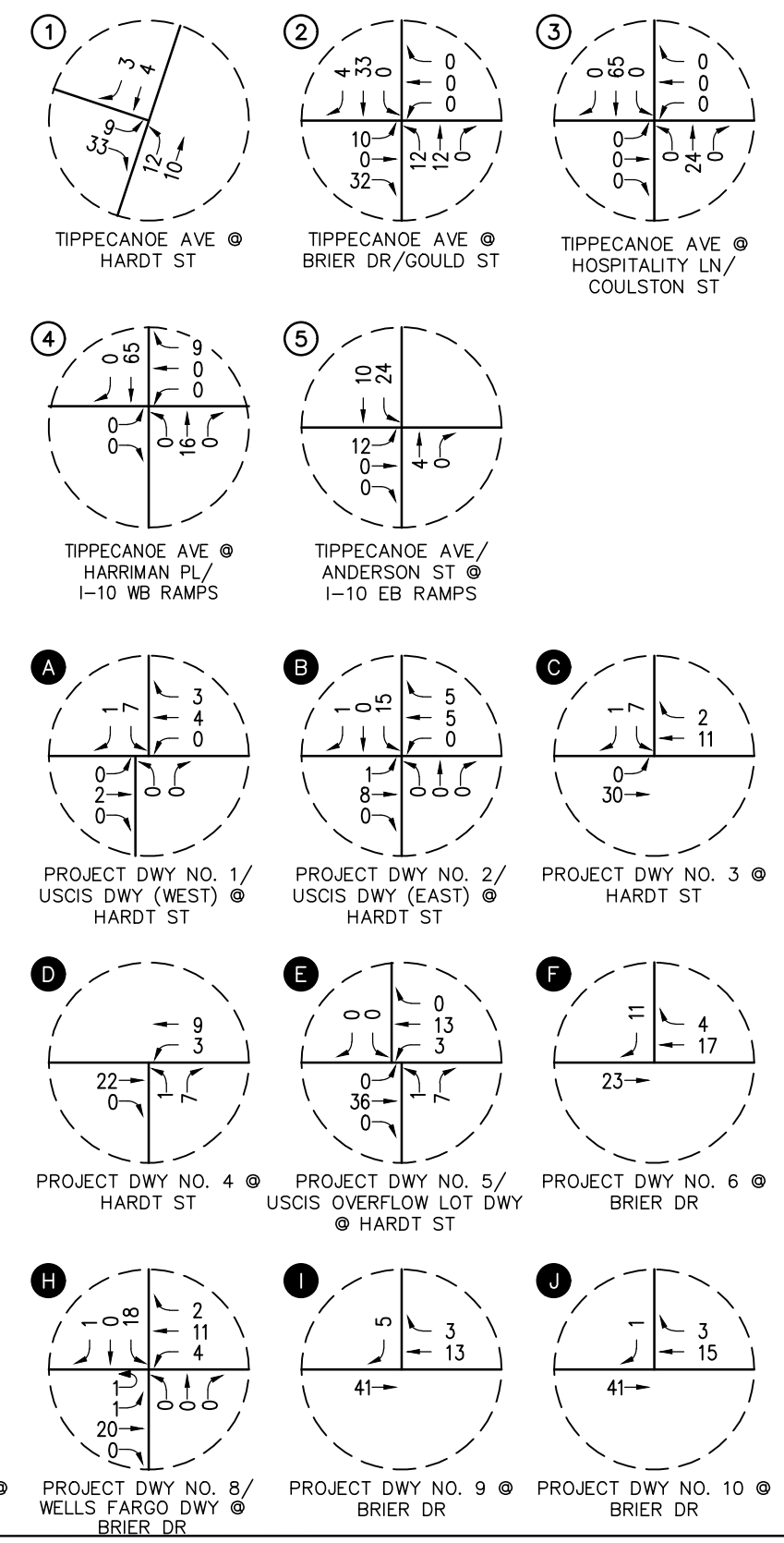
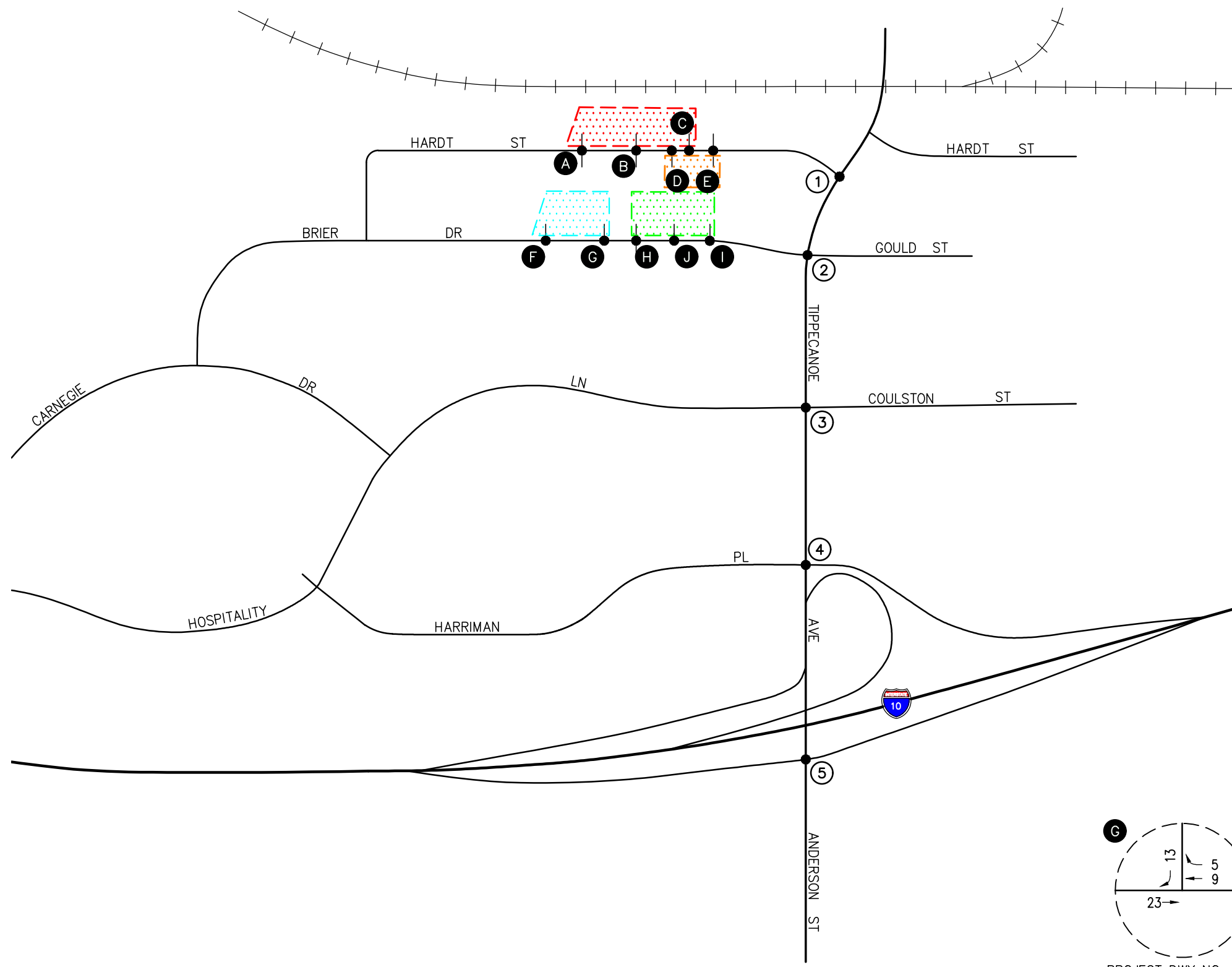
**KEY**

- ⊙ = STUDY INTERSECTION
- ++ = RAILROAD TRACKS
- ↔ = INBOUND PERCENTAGE
- ← = OUTBOUND PERCENTAGE
- ▒ = BUILDING E

**FIGURE 5-4**

**PROJECT TRAFFIC DISTRIBUTION PATTERN (BUILDING E)**  
HARDT AND BRIER BUSINESS PARK PROJECT, SAN BERNARDINO

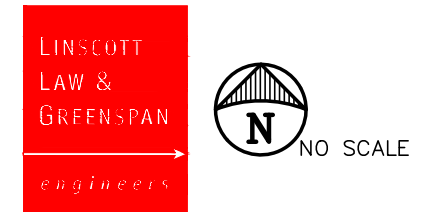




- KEY**
- # = STUDY INTERSECTION
  - + + = RAILROAD TRACKS
  - [Red Dotted Box] = BUILDINGS A & B
  - [Orange Dotted Box] = BUILDING C
  - [Green Dotted Box] = BUILDINGS D1 AND D2
  - [Blue Dotted Box] = BUILDING E

**FIGURE 5-6**

**PM PEAK HOUR PROJECT TRAFFIC VOLUMES**  
HARDT AND BRIER BUSINESS PARK PROJECT, SAN BERNARDINO



## 6.0 FUTURE TRAFFIC CONDITIONS

### 6.1 Existing With Project Traffic Volumes

The estimates of Project generated traffic volumes were added to the Existing traffic conditions to develop traffic projections for Existing With Project traffic conditions. *Figures 6-1* and *6-2* present the anticipated AM and PM peak hour Existing With Project traffic volumes, respectively, at the five (5) key study intersections.

### 6.2 Year 2025 Without Project Traffic Volumes

#### 6.2.1 Ambient Growth Traffic

Near-term horizon year, traffic growth estimates have been calculated using an ambient growth factor. The ambient growth factor is intended to include unknown and future cumulative projects in the study area, as well as account for regular growth in traffic volumes due to the development of projects outside the study area. The application of the three percent (3.0%) annual growth rate to baseline traffic volumes results in a nine percent (9.0%) growth in existing baseline volumes at the five (5) key study intersections to horizon Year 2025.

#### 6.2.2 Cumulative Projects Traffic

In order to make a realistic estimate of future on-street conditions prior to implementation of the proposed Project, the status of other known development projects (cumulative projects) in the vicinity of the proposed Project has been researched at the Cities of San Bernardino, Loma Linda, Redlands and Highland. With this information, the potential impact of the proposed Project can be evaluated within the context of the cumulative impact of all ongoing development. Based on our research, there are twenty-three (23) cumulative projects in the City of San Bernardino, eight (8) cumulative projects in the City of Loma Linda, one (1) cumulative project in the City of Redlands and one (1) cumulative project in the City of Highland within the vicinity of the subject site. These thirty-three (33) planned and/or approved cumulative projects have been included as part of the cumulative background setting. The locations of the thirty-three (33) cumulative projects are presented in *Figure 6-3*.

*Table 6-1* presents the jurisdiction, description and development totals for each of the thirty-three (33) cumulative projects. *Table 6-2* presents the resultant trip generation for the thirty-three (33) cumulative projects. As shown in *Table 6-2*, the thirty-three (33) cumulative projects are expected to generate 47,556 daily trips (one half arriving, one half departing), with 4,673 trips (2,609 inbound and 2,064 outbound) forecast during the AM peak hour and 3,707 trips (1,708 inbound and 1,999 outbound) forecast during the PM peak hour on a “typical” weekday.

The anticipated AM and PM peak hour cumulative projects traffic volumes at the five (5) key study intersections are presented in *Figures 6-4* and *6-5*, respectively.

*Figures 6-6* and *6-7* present Year 2025 Without Project AM and PM peak hour traffic volumes at the five (5) key study intersections, respectively. It should be noted that the Year 2025 Without

Project traffic volumes include ambient traffic growth as well as the traffic from the thirty-three (33) cumulative projects.

It should again be emphasized that because this traffic impact analysis utilizes both an ambient growth factor along with a list of cumulative projects approach to analyze cumulative impacts, this traffic impact analysis is highly conservative and would tend to overstate cumulative traffic impacts.

### **6.3 Year 2025 With Project Traffic Volumes**

The estimates of Project generated traffic volumes were added to the Year 2025 Without Project traffic conditions to develop traffic projections for Year 2025 With Project traffic conditions. *Figures 6-8* and *6-9* present the anticipated AM and PM peak hour Year 2025 With Project traffic volumes at the five (5) key study intersections, respectively.

### **6.4 Buildout Traffic Conditions**

As directed by City of San Bernardino staff, long-term (Buildout) traffic volume forecasts were determined through utilization of the San Bernardino Traffic Analysis Model (SBTAM). The future Year 2040 traffic volumes were post-processed based on the relationship of Year 2012 base year validation model run output to the base year ground traffic counts. The projected volumes were reviewed carefully and adjustments were applied as warranted based on local conditions and professional judgment. Copies of the traffic model post-processing worksheets for Buildout (Year 2040) are contained in *Appendix C*.

#### **6.4.1 Volume Adjustment**

Using the SBTAM, projected traffic volumes were obtained for each intersection. The first step is to obtain the approach and departure volumes from the model for each leg of the analyzed intersections. The next step is to determine the difference between the base year peak hour model volumes and the build-out peak hour model volumes. This “difference” represents the projected growth in traffic on each approach from the base year to the build-out using the SBTAM.

#### **6.4.2 B-turn Methodology**

The base year turning movement counts for each intersection must be converted to approach and departure volumes for each leg of the intersection. Once the base counts are in this format, the difference between the build-out model and base model are then added to the base year counts for each corresponding approach and departure volume. This step provides the adjusted volumes that will be used to determine the build-out turning movement volumes. The next process in the forecasting of future turning volumes applies the B-turn methodology. The B-turn methodology is generally described in the “*National Cooperative Highway Research Program Report (NCHRP) 255: Highway Traffic Data for Urbanized Area Project Planning and Design*”, Chapter 8. The B-turn method uses the base year turning percentages (from traffic counts) and proceeds through an iterative computational technique to produce a final set of future year turning volumes. The computations involve alternatively balancing the rows (approaches) and the columns (departures) of a turning movement matrix until an acceptable convergence is obtained. Future year link volumes

are fixed using this method and the turning movements are adjusted to match. The results must be checked for reasonableness and manual adjustments are sometimes necessary.

Projected volumes were reviewed carefully and adjustments were applied as warranted based on local conditions and professional engineering judgment. Please note that the post-processing methodology utilized in this report is consistent with SCAG/SANBAG requirements.

## **6.5 Buildout Traffic Volumes**

The anticipated AM and PM peak hour traffic volumes, at the key study intersections, associated with Buildout traffic conditions are presented in *Figures 6-10* and *6-11*, respectively.

*Figures 6-12* and *6-13* illustrate the Buildout With Project Traffic Conditions during the AM peak hour and PM peak hour, respectively.



**TABLE 6-1  
LOCATION AND DESCRIPTION OF CUMULATIVE PROJECTS<sup>6</sup>**

No.	Description	Location/Address	Size
<b><u>City of San Bernardino</u></b>			
1.	CUP 18-05 / PCNL 18-04	NWC of E. Central Avenue and S. Tippecanoe Avenue	1,900 SF Retail 1,200 SF Fast Food Rest. without Drive-Thru 2,550 SF Fast Food Rest. with Drive-Thru 20 VFP Gas Station 12 VFP Gas Station Diesel 3,800 SF Convenience Store 140' Tunnel Express Carwash
2.	CUP 18-17	SWC of E. Mill St & S. Waterman Ave	24,630 SF Truck Storage & Service Facility (8 Acres)
3.	CUP 18-21	1150 and 1250 S. Tippecanoe Avenue	Increased Daily Tonnage (900 Tons to 1,500 Tons)
4.	CUP 17-09 / CUP 17-29 / PCNL 18-03	1195 S. Waterman Avenue	12 VFP Gas Station 3 VFP Diesel Truck Fueling Station 3,806 SF Convenience Store
5.	GPA 19-03 / DCA 19-08 / Subdivision 19-16 / DP Type-D 19-13	SEC of S. Foisy St and E. Central Ave	467,280 SF Warehouse
6.	Subdivision 18-04 / Subdivision 18-05 / DP Type-D 18-04	SEC of S. Washington Avenue and E. Central Avenue	287,184 SF Warehouse (107,600 SF Building 1 & 179,584 SF Building 2)
7.	Subdivision 18-06 / Subdivision 18-07 / DP Type-D 18-05	SWC of S. Washington Avenue and E. Central Avenue	287,800 SF Warehouse (141,000 SF Building 1 & 146,800 SF Building 2)
8.	Subdivision 20-05 / CUP 20-13	SEC of W. Redlands Boulevard and S. Hunts Lane	12 VFP Gas Station 4,650 SF Convenience Store 5,000 SF Fast Food Rest. with Drive-Thru
9.	Chick-fil-A San Bernardino Project	1050 Harriman Place	4,562 SF Chick-fil-A with Drive-Thru
10.	GPA 19-01 / DCA 19-05 / Subdivision 19-03 / CUP 19-10	230 S. Waterman Avenue	100 Student Private School (K-8) 714 Student Private School (K-12)
11.	CUP 17-23	205 and 215 E. Hospitality Lane	98-Room Hotel Conversion of an Existing 154-Room Hotel into a 106-Room Hotel
12.	CUP 19-20 / ME 19-02	South side of E. Brier Drive, at the intersection of S. Gifford Avenue	113-Room Hotel
13.	CUP 20-15	488 W. Mill Street	Express Drive-Through Car Wash Facility with a 65-Foot Tunnel

<sup>6</sup> Source: Cities of San Bernardino, Loma Linda, Redlands and Highland Planning Department staff.

**TABLE 6-1 (CONTINUED)**  
**LOCATION AND DESCRIPTION OF CUMULATIVE PROJECTS<sup>7</sup>**

No.	Description	Location/Address	Size
14.	CUP21-01	SEC of W/ Hospitality Lane and S. Waterman Avenue	2,050 SF Fast Food Rest. with Drive-Thru
15.	DP-D 19-11	1065 S. Waterman Avenue	9,385 SF Office
16.	DP-D 20-11	North side of E. Cooley Avenue, west of S. Tippecanoe Avenue	3.41-Acre Truck and Trailer Parking Facility
17.	DP-D 21-05	998 S. Sierra Way	8,085 SF Warehouse (Addition to an existing warehouse facility)
18.	DP-D 21-13	1223 E. Davidson Street and 24990 E. Coulston Street	10 DU Multifamily
19.	DP-D 21-14	682 S. Valley View Avenue	65,963 SF Warehouse
20.	GPA 20-03 / DZA (ZMA) 20-04 / Subdivision 20-03 (TPM 20293) / DP-P 20-02	East side of S. Ferree Street, south of the terminus of E. Laurelwood Drive	96 DU Single-Family Detached
21.	Subdivision 20-08 (TPM 20320) and 20-15	NEC of E. Central Avenue and S. Foisy Street	104,850 SF Warehouse
22.	Subdivision 21-05 (TPM 20392) and DP-D 21-07	NEC of E. Norman Road and S. Lena Road	231,436 SF Warehouse
23.	CNG Fueling Station	NWC of Tippecanoe Avenue and Central Avenue	4 Fast-fill CNG dispensers 215 Time Fill Posts for Trucks
<b><u>City of Loma Linda</u></b>			
24.	Candlewood Suites Hotel	Richardson Street & Redlands Boulevard	91-Room Hotel
25.	California Eye Care Center	25258 Redlands Boulevard	30,382 SF Eye Care Center
26.	Lewis's 57 Condo Units	SWC of Redlands Blvd & Bryn Mawr	57 DU Multifamily
27.	Courtyard Marriot Hotel	10372 Richardson Street	125-Room Hotel
28.	O'Reilly's Auto Parts	25630 Redlands Boulevard	7,564 SF O'Reilly Auto Parts Store
29.	Redlands Boulevard Motel	24850 Redlands Boulevard	23-Room Motel
30.	Cottage Street Residential	25239 Cottage Street	23 DU Multifamily
31.	CA Highway Patrol Facility	Bryn Mawr & Redlands Boulevard	39,285 SF Patrol Facility

<sup>7</sup> Source: Cities of San Bernardino, Loma Linda, Redlands and Highland Planning Department staff.

**TABLE 6-1 (CONTINUED)**  
**LOCATION AND DESCRIPTION OF CUMULATIVE PROJECTS<sup>8</sup>**

No.	Description	Location/Address	Size
<b><u>City of Redlands</u></b>			
32.	Planned Development No. 4	NEC of Mountain View Ave & Interstate 10	420,000 SF Warehousing
<b><u>City of Highland</u></b>			
33.	Sterling Natural Resource Center	NWC of 5 <sup>th</sup> Street at Del Rosa Drive	12,500 SF Administration Center

<sup>8</sup> Source: Cities of San Bernardino, Loma Linda, Redlands and Highland Planning Department staff.

**TABLE 6-2  
CUMULATIVE PROJECTS TRAFFIC GENERATION FORECAST<sup>9</sup>**

No.	Cumulative Project Description	Daily Two-Way	AM Peak Hour			PM Peak Hour		
			In	Out	Total	In	Out	Total
1.	CUP 18-05 / PCNL 18-04 <sup>10</sup>	13,398	541	533	1,074	610	605	1,215
2.	CUP 18-17 <sup>11</sup>	1,310	16	27	43	41	23	64
3.	CUP 18-21 <sup>12</sup>	1,076	39	39	78	83	83	166
4.	CUP 17-09/CUP 17-29/PCNL 18-03 <sup>13</sup>	3,251	68	68	136	96	96	192
5.	GPA 19-03/DCA 19-08/Subdivision 19-16/DP Type-D 19-13 <sup>14</sup>	1,098	83	24	107	33	88	121
6.	Subdivision 18-04/Subdivision 18-05/DP Type-D 18-04 <sup>15</sup>	1,379	92	24	116	32	94	126
7.	Subdivision 18-06/Subdivision 18-07/DP Type-D 18-05 <sup>16</sup>	1,384	92	24	116	32	94	126
8.	Subdivision 20-05 / CUP 20-13 <sup>17</sup>	5,649	125	123	248	113	109	222
9.	Chick-fil-A San Bernardino Project <sup>18</sup>	1,611	47	46	93	38	36	74
10.	GPA 19-01/DCA 19-05/Subdivision 19-03/CUP 19-10 <sup>19</sup>	5,906	967	779	1,746	173	210	383
11.	CUP 17-23	400	12	11	23	16	14	30
12.	CUP 19-20 / ME 19-02	903	29	23	52	34	33	67
13.	CUP 20-15	422	13	10	23	22	22	44
14.	CUP21-01	718	23	22	45	16	15	31
15.	DP-D 19-11	102	12	2	14	2	12	14
16.	DP-D 20-11	129	0	8	8	1	6	7
17.	DP-D 21-05	14	1	0	1	0	1	1
18.	DP-D 21-13	67	1	3	4	3	2	5
19.	DP-D 21-14	113	8	3	11	3	9	12
20.	GPA 20-03 / DZA (ZMA) 20-04 / Subdivision 20-03 (TPM 20293) / DP-P 20-02	905	17	50	67	57	33	90
21.	Subdivision 20-08 (TPM 20320) and 20-15	179	14	4	18	5	14	19
22.	Subdivision 21-05 (TPM 20392) and DP-D 21-07	396	30	9	39	12	30	42

<sup>9</sup> Unless otherwise noted, Source: *Trip Generation, 11<sup>th</sup> Edition*, Institute of Transportation Engineers (ITE) [Washington, D.C. (2021)].

<sup>10</sup> Source: *Fuel Center and Convenience Store Traffic Impact Analysis*, prepared by Urban Crossroads, dated October 3, 2018.

<sup>11</sup> Source: *Waterman & Mill Truck Repair Facility TIA Scope of Study Form*, prepared by Urban Crossroads, dated January 2, 2019.

<sup>12</sup> Source: *East Valley Recycling Center Expansion Traffic Impact Analysis*, prepared by Urban Crossroads, dated July 29, 2019.

<sup>13</sup> Source: *Proposed Waterman Ave/Orange Show Rd Gas Station Project TIS*, prepared by RK Engineering Group, Inc., dated Feb. 20, 2018.

<sup>14</sup> Source: *Foisy East Warehouse Traffic Impact Study*, prepared by Kimley Horn, dated June 2020.

<sup>15</sup> Source: *Washington Commerce Center East Traffic Impact Study*, prepared by Kimley Horn, dated July 2018.

<sup>16</sup> Source: *Washington Commerce Center West Traffic Impact Study*, prepared by Kimley Horn, dated July 2018.

<sup>17</sup> Source: *TIS for the Proposed SEC of Hunts and Redlands Retail Project*, prepared by Kimley Horn, dated November 2020.

<sup>18</sup> Source: *Chick-Fil-A San Bernardino TIA*, prepared by LLG Engineers, dated July 2021.

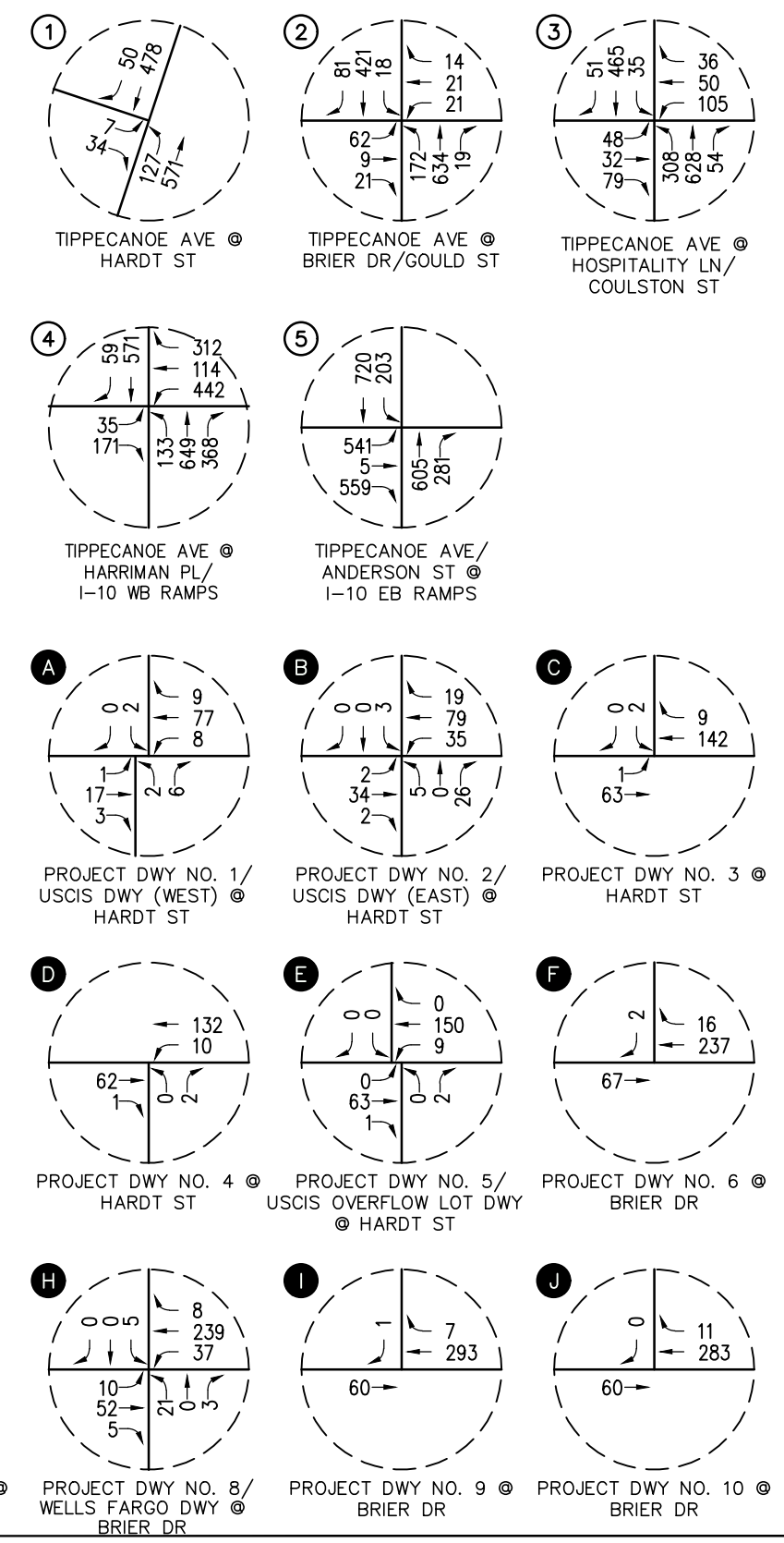
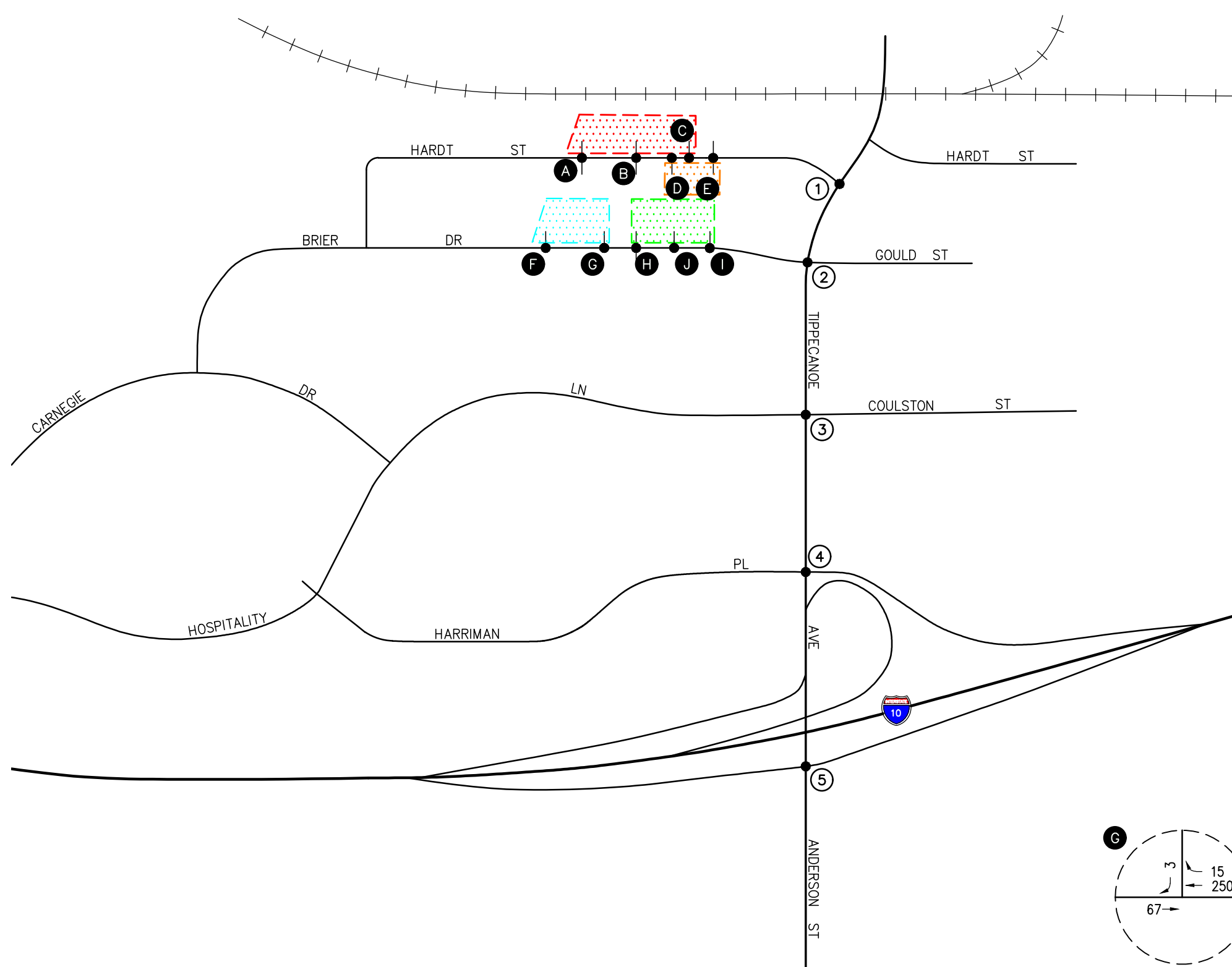
<sup>19</sup> Source: *Norton Science and Language Academy Traffic Impact Study*, prepared by Kimley Horn, dated November 2019.

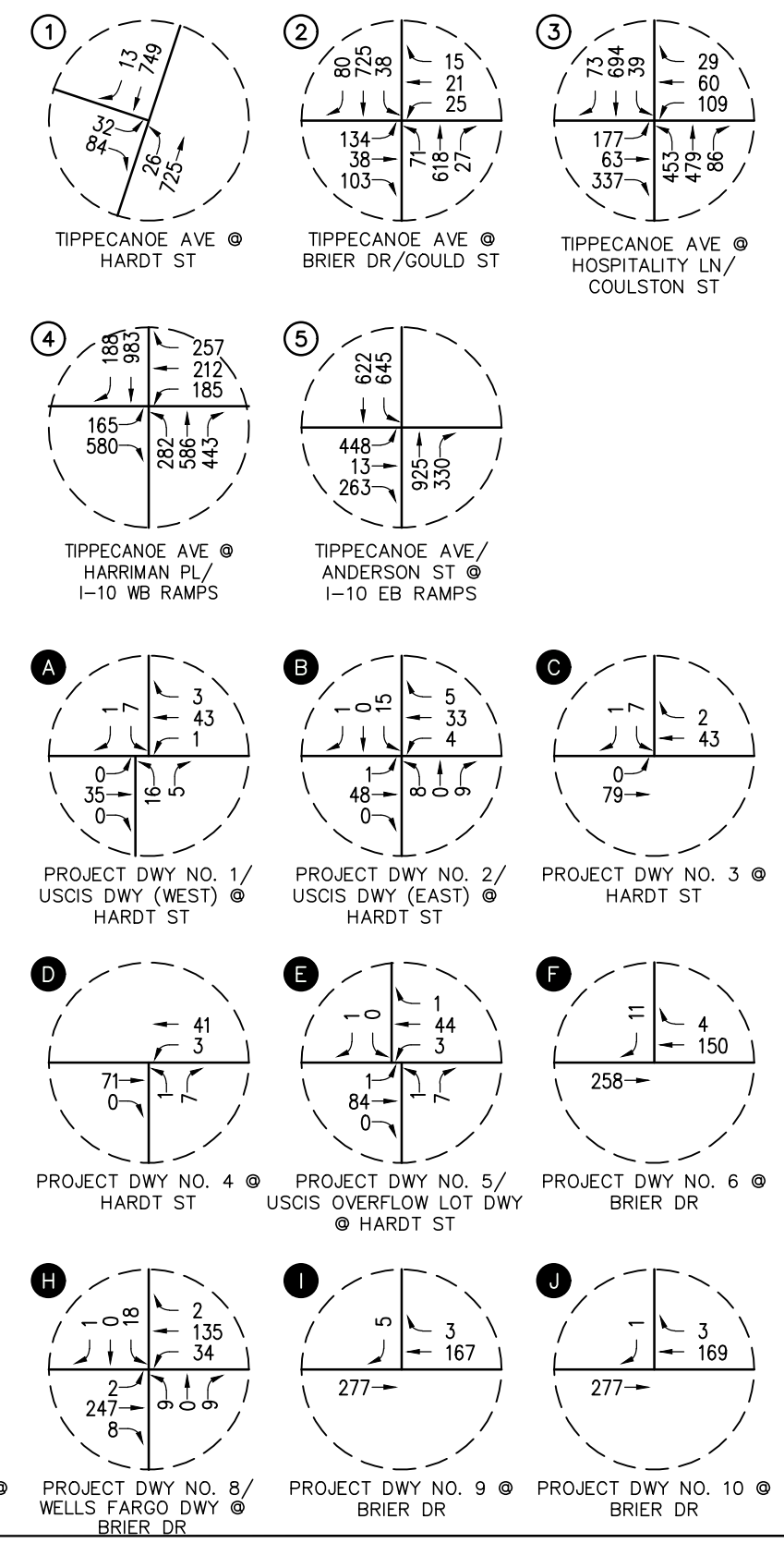
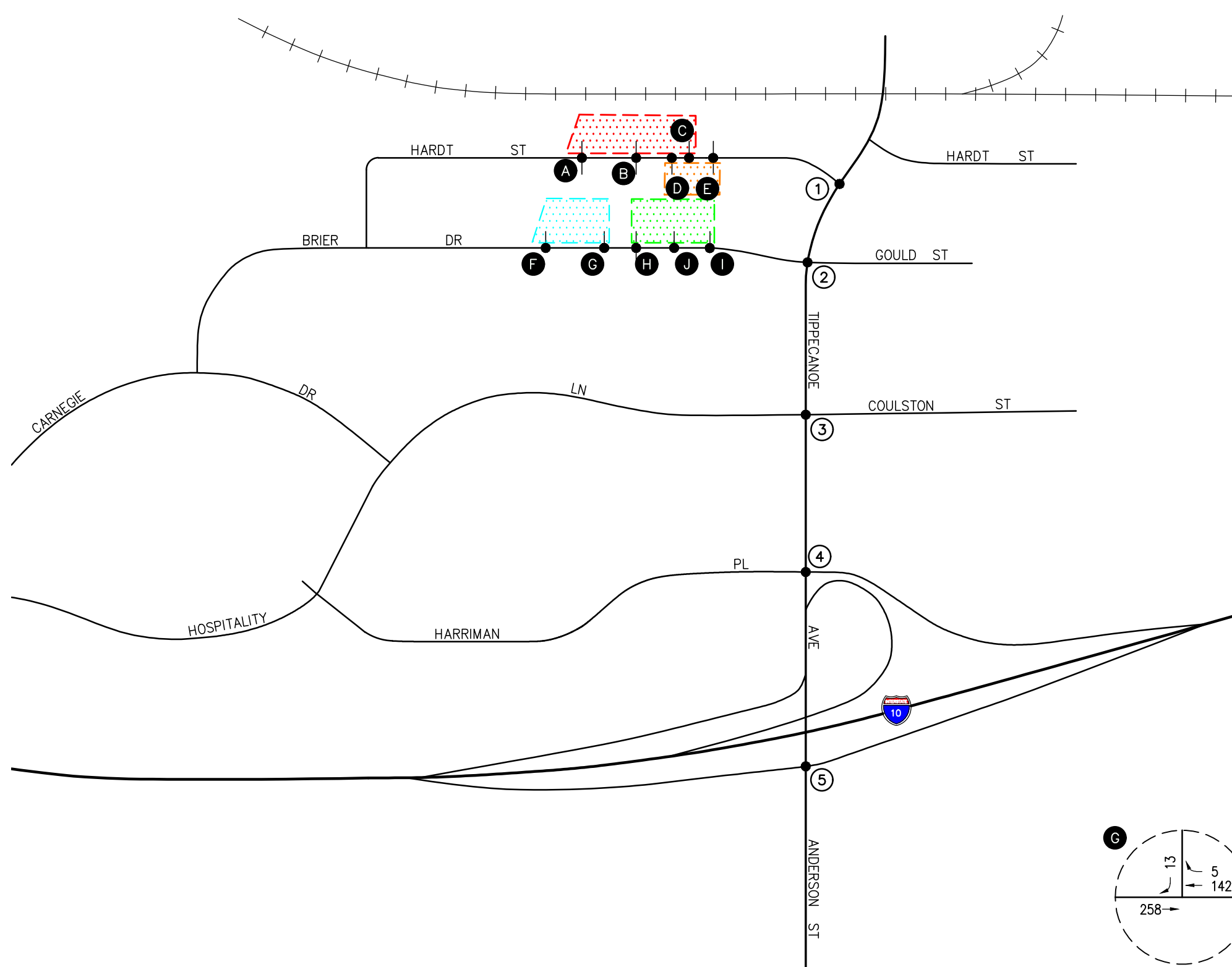
**TABLE 6-2 (CONTINUED)**  
**CUMULATIVE PROJECTS TRAFFIC GENERATION FORECAST<sup>20</sup>**

No.	Cumulative Project Description	Daily Two-Way	AM Peak Hour			PM Peak Hour		
			In	Out	Total	In	Out	Total
23.	CNG Fueling Station <sup>21</sup>	1,597	59	80	139	103	75	178
24.	Candlewood Suites Hotel	727	24	18	42	28	26	54
25.	California Eye Care Center	1,094	74	20	94	36	83	119
26.	Lewis's 57 Condo Units	384	6	17	23	18	11	29
27.	Courtyard Marriot Hotel	999	32	26	58	38	36	74
28.	O'Reilly's Auto Parts	372	9	8	17	10	11	21
29.	Redlands Boulevard Motel	77	3	5	8	4	4	8
30.	Cottage Street Residential	155	2	7	9	8	4	12
31.	CA Highway Patrol Facility	887	98	33	131	17	50	67
32.	Planned Development No. 4	718	55	16	71	21	55	76
33.	Sterling Natural Resource Center	136	17	2	19	3	15	18
<b>Total Cumulative Projects Trip Generation Forecast</b>		<b>47,556</b>	<b>2,609</b>	<b>2,064</b>	<b>4,673</b>	<b>1,708</b>	<b>1,999</b>	<b>3,707</b>

<sup>20</sup> Unless otherwise noted, Source: *Trip Generation, 11<sup>th</sup> Edition*, Institute of Transportation Engineers (ITE) [Washington, D.C. (2021)].

<sup>21</sup> Source: *CNG Fueling Station Project TIA*, prepared by LLG Engineers, dated September 2021.

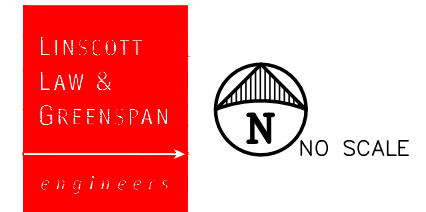




- KEY**
- # = STUDY INTERSECTION
  - + + = RAILROAD TRACKS
  - [Red Dotted Box] = BUILDINGS A & B
  - [Orange Dotted Box] = BUILDING C
  - [Green Dotted Box] = BUILDINGS D1 AND D2
  - [Blue Dotted Box] = BUILDING E

**FIGURE 6-2**

**EXISTING WITH PROJECT PM PEAK HOUR TRAFFIC VOLUMES**  
HARDT AND BRIER BUSINESS PARK PROJECT, SAN BERNARDINO





**KEY**

1. CUP 18-05/PCNL 18-04
2. CUP 18-17
3. CUP 18-21
4. CUP 17-09/CUP 17-29/  
PCNL 18-03
5. GPA 19-03/DCA 19-08/  
SUBDIVISION 19-16/  
DP TYPE-D 19-13
6. SUBDIVISION 18-04/  
SUBDIVISION 18-05/  
DP TYPE-D 18-04
7. SUBDIVISION 18-06/  
SUBDIVISION 18-07/  
DP TYPE-D 18-05
8. SUBDIVISION 20-05/CUP 20-13
9. CHICK-FIL-A  
SAN BERNARDINO PROJECT
10. GPA 19-01/DCA 19-05/  
SUBDIVISION 19-03/CUP 19-10
11. CUP 17-23
12. CUP 19-20/ME 19-02
13. CUP 20-15
14. CUP 21-01
15. DP-D 19-11
16. DP-D 20-11
17. DP-D 21-05
18. DP-D 21-13
19. DP-D 21-14
20. GPA 20-03/DZA(ZMA) 20-04/  
SUBDIVISION 20-03  
(TPM 20293)/DP-P 20-02
21. SUBDIVISION 20-08(TPM 20320)  
AND 20-15
22. SUBDIVISION 21-05(TPM 20392)  
AND DP-D 21-07
23. CNG FUELING STATION
24. CANDLEWOOD SUITES HOTEL
25. CALIFORNIA EYE CARE CENTER
26. LEWIS'S 57 CONDO UNITS
27. COURTYARD MARRIOTT HOTEL
28. O'REILLY'S AUTO PARTS
29. REDLANDS BOULEVARD MOTEL
30. COTTAGE STREET RESIDENTIAL
31. CA HIGHWAY PATROL FACILITY
32. PLANNED DEVELOPMENT NO.4
33. STERLING NATURAL RESOURCE CENTER

n:\4500\2214502 - hardt and brier business park project, san bernardino\dwg\4502\_f6-3.dwg LDP 16:20:11 03-13-2023 kopulsky

**LINSCOTT  
LAW &  
GREENSPAN**  
engineers

NO SCALE

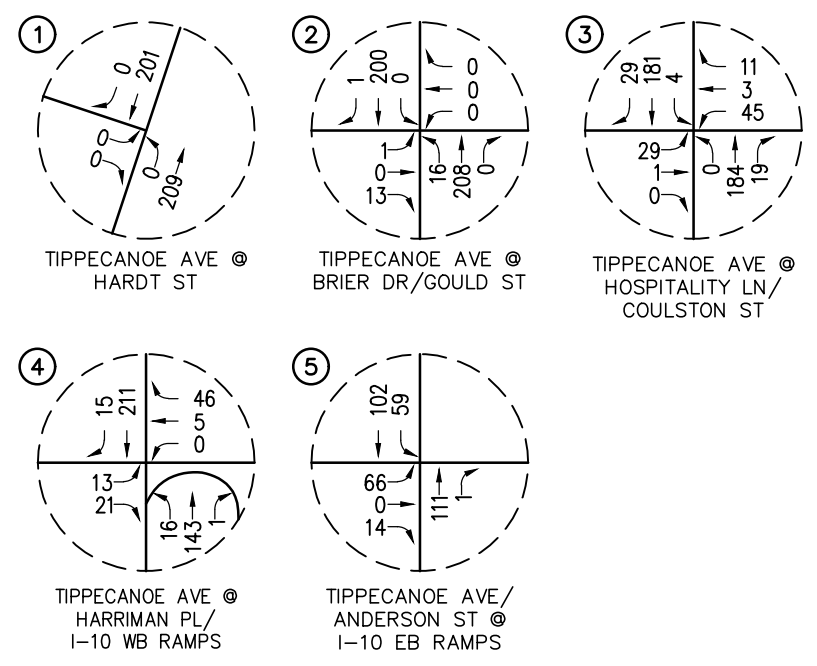
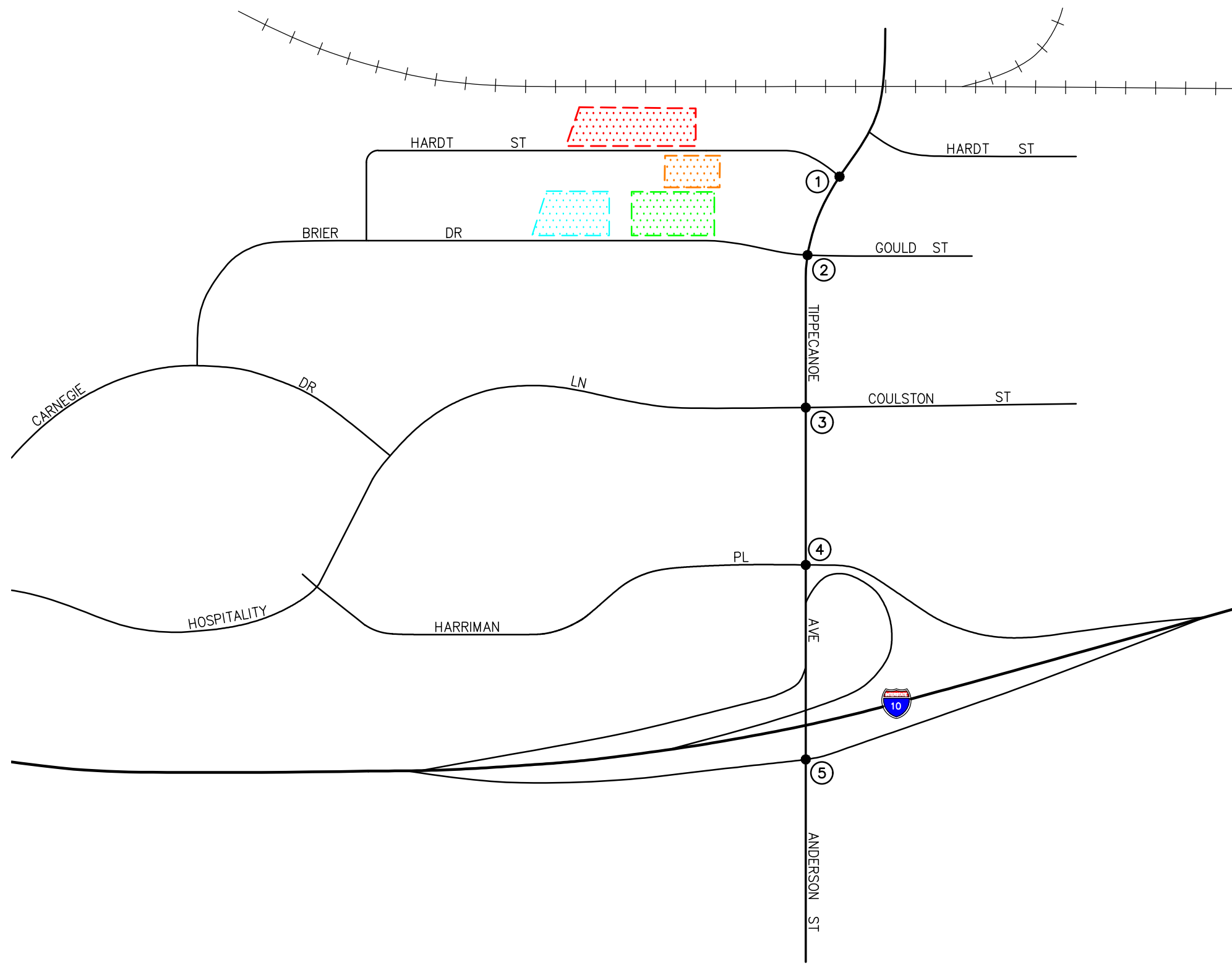
SOURCE: GOOGLE  
KEY

- # = CUMULATIVE PROJECT LOCATION
- [Red pattern] = BUILDINGS A & B
- [Orange pattern] = BUILDING C
- [Green pattern] = BUILDINGS D1 & D2
- [Blue pattern] = BUILDING E

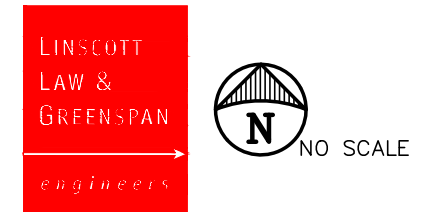
**FIGURE 6-3**

**LOCATION OF CUMULATIVE PROJECTS  
HARDT AND BRIER BUSINESS PARK PROJECT, SAN BERNARDINO**





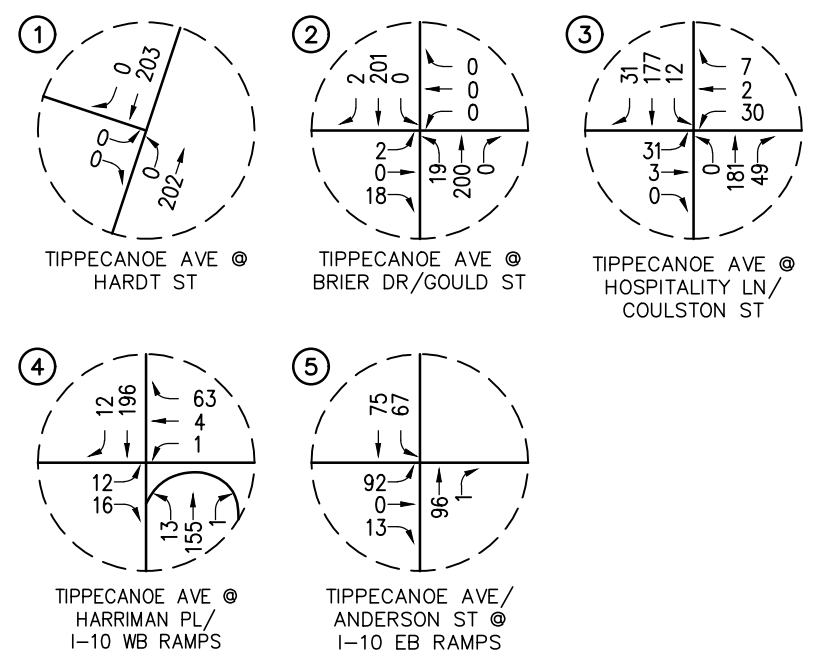
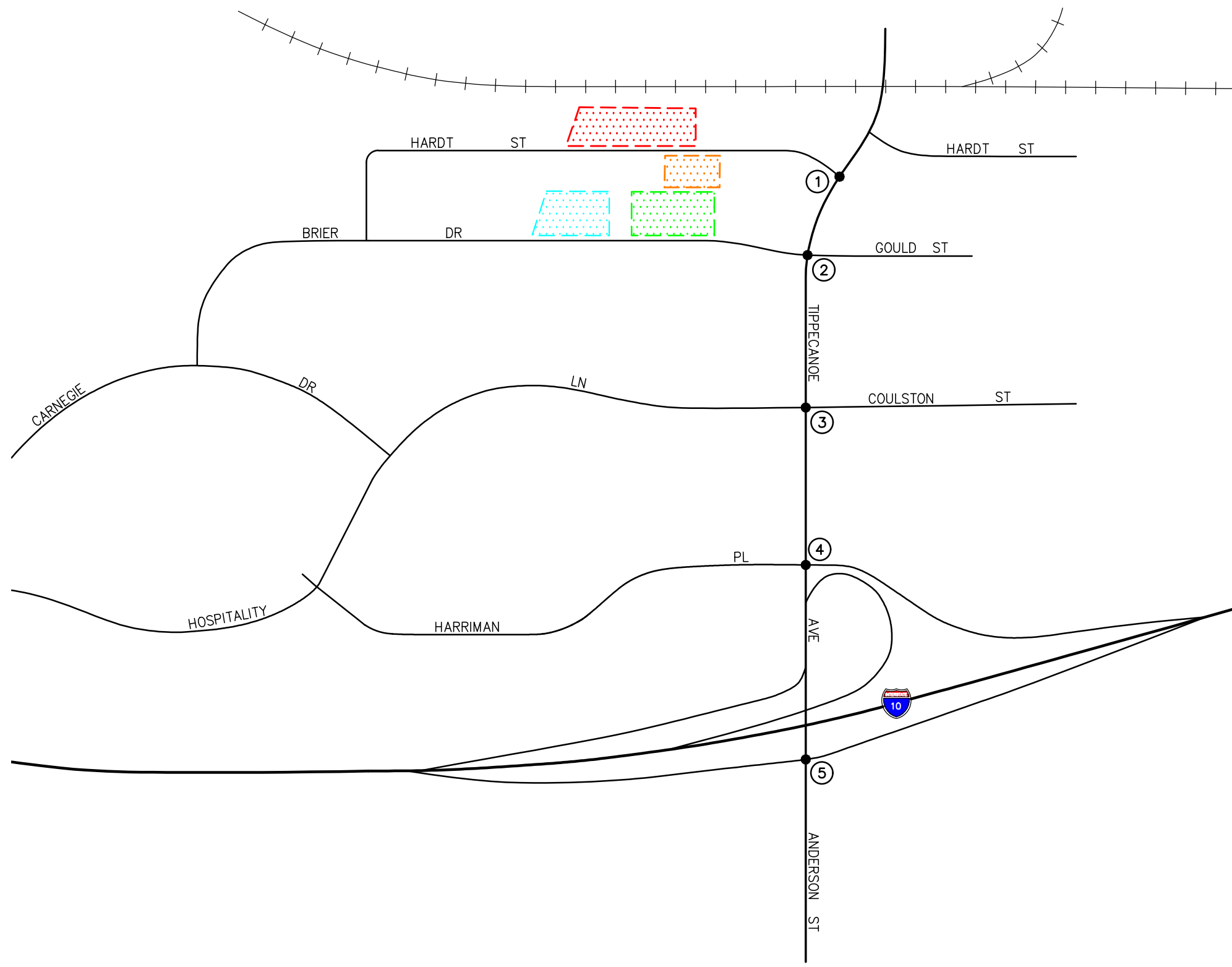
n:\4500\2214502 - hardt and brier business park project, san bernardino\dwg\4502 f6-4.dwg LDP 16:21:33 03-13-2023 kopulsky



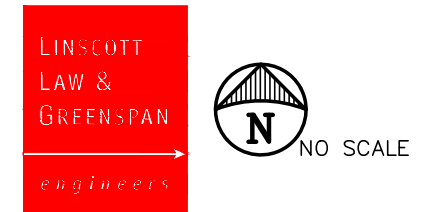
- KEY**
- # = STUDY INTERSECTION
  - + + = RAILROAD TRACKS
  - [Red Hatched Box] = BUILDINGS A & B
  - [Orange Hatched Box] = BUILDING C
  - [Green Hatched Box] = BUILDINGS D1 & D2
  - [Cyan Hatched Box] = BUILDING E

**FIGURE 6-4**

**AM PEAK HOUR CUMULATIVE PROJECTS TRAFFIC VOLUMES**  
HARDT AND BRIER BUSINESS PARK PROJECT, SAN BERNARDINO



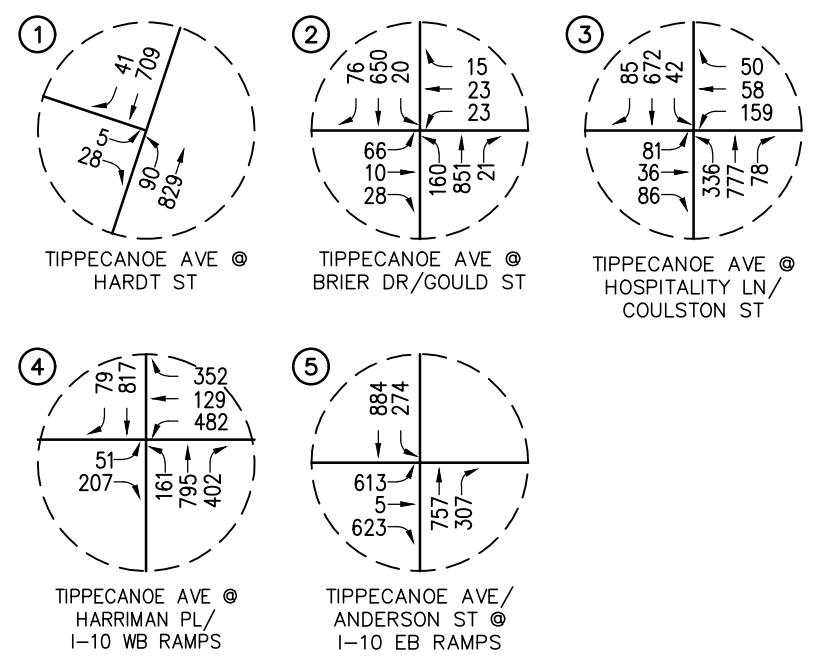
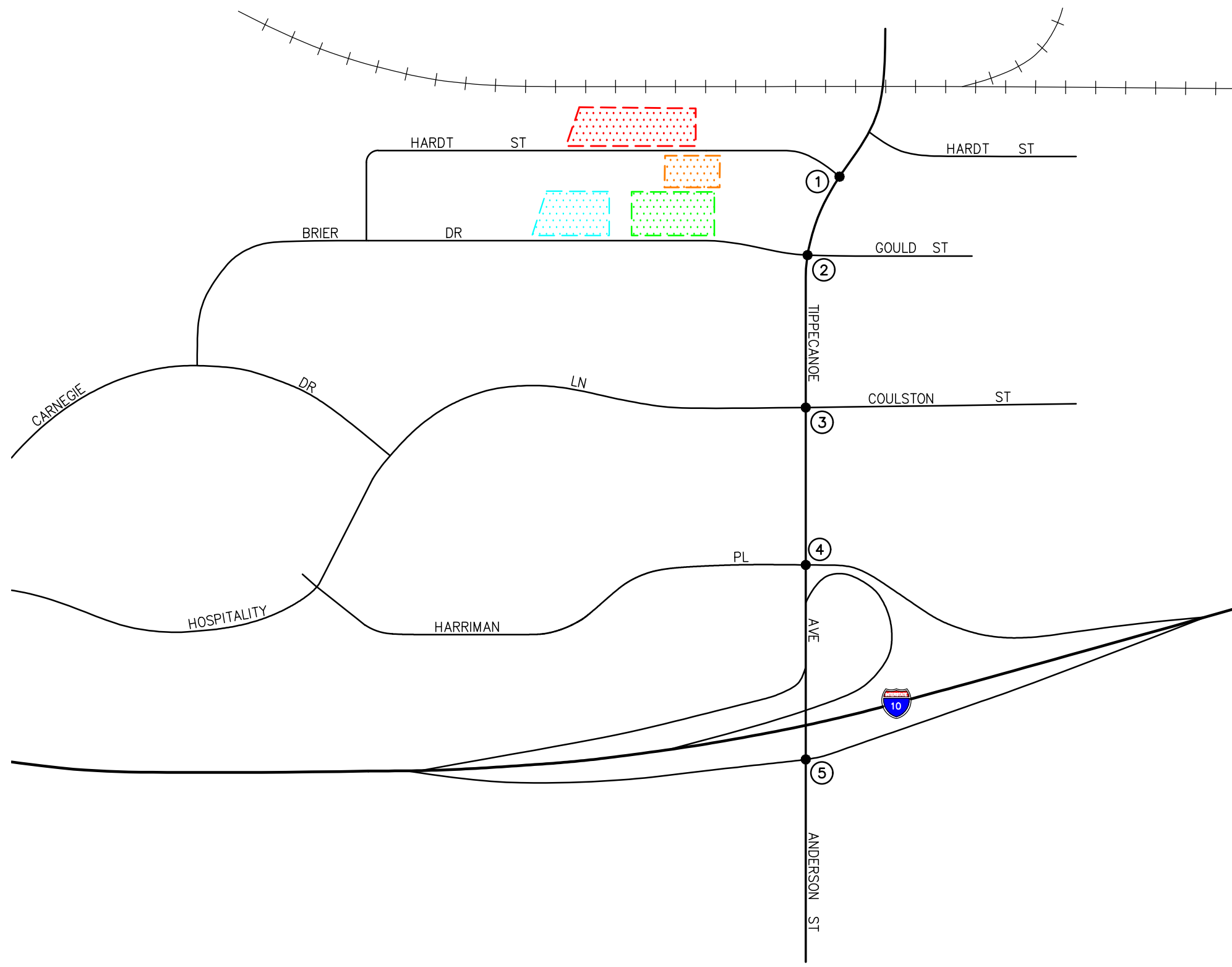
n:\4500\2214502 - hardt and brier business park project, san bernardino\dwg\4502 f6-5.dwg LDP 16:22:09 03-13-2023 kopulsky



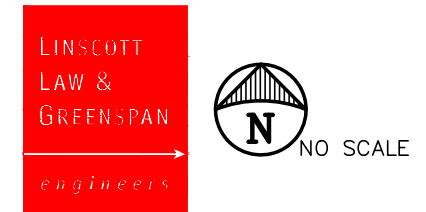
- KEY**
- # = STUDY INTERSECTION
  - + + = RAILROAD TRACKS
  - [Red dotted pattern] = BUILDINGS A & B
  - [Orange dotted pattern] = BUILDING C
  - [Green dotted pattern] = BUILDINGS D1 & D2
  - [Cyan dotted pattern] = BUILDING E

**FIGURE 6-5**

**PM PEAK HOUR CUMULATIVE PROJECTS TRAFFIC VOLUMES**  
HARDT AND BRIER BUSINESS PARK PROJECT, SAN BERNARDINO



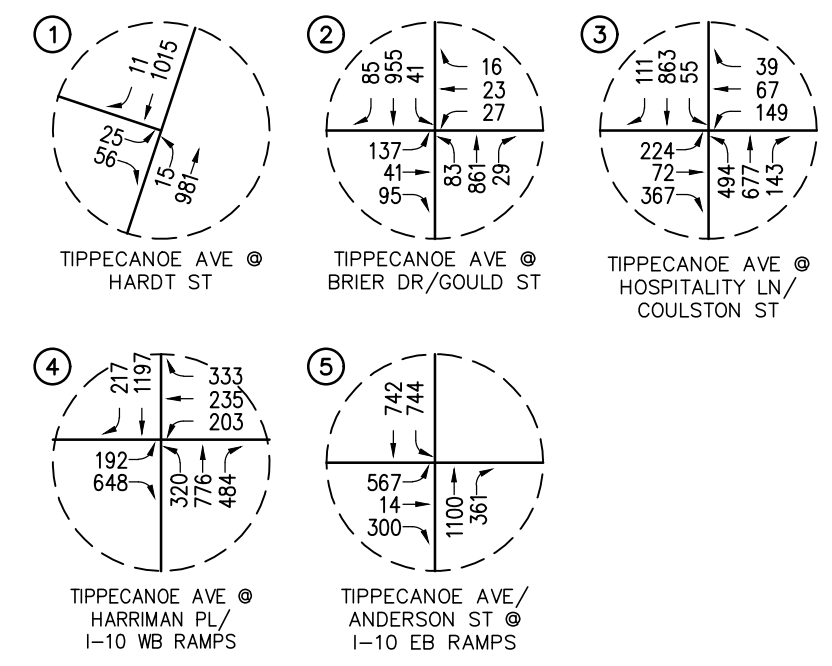
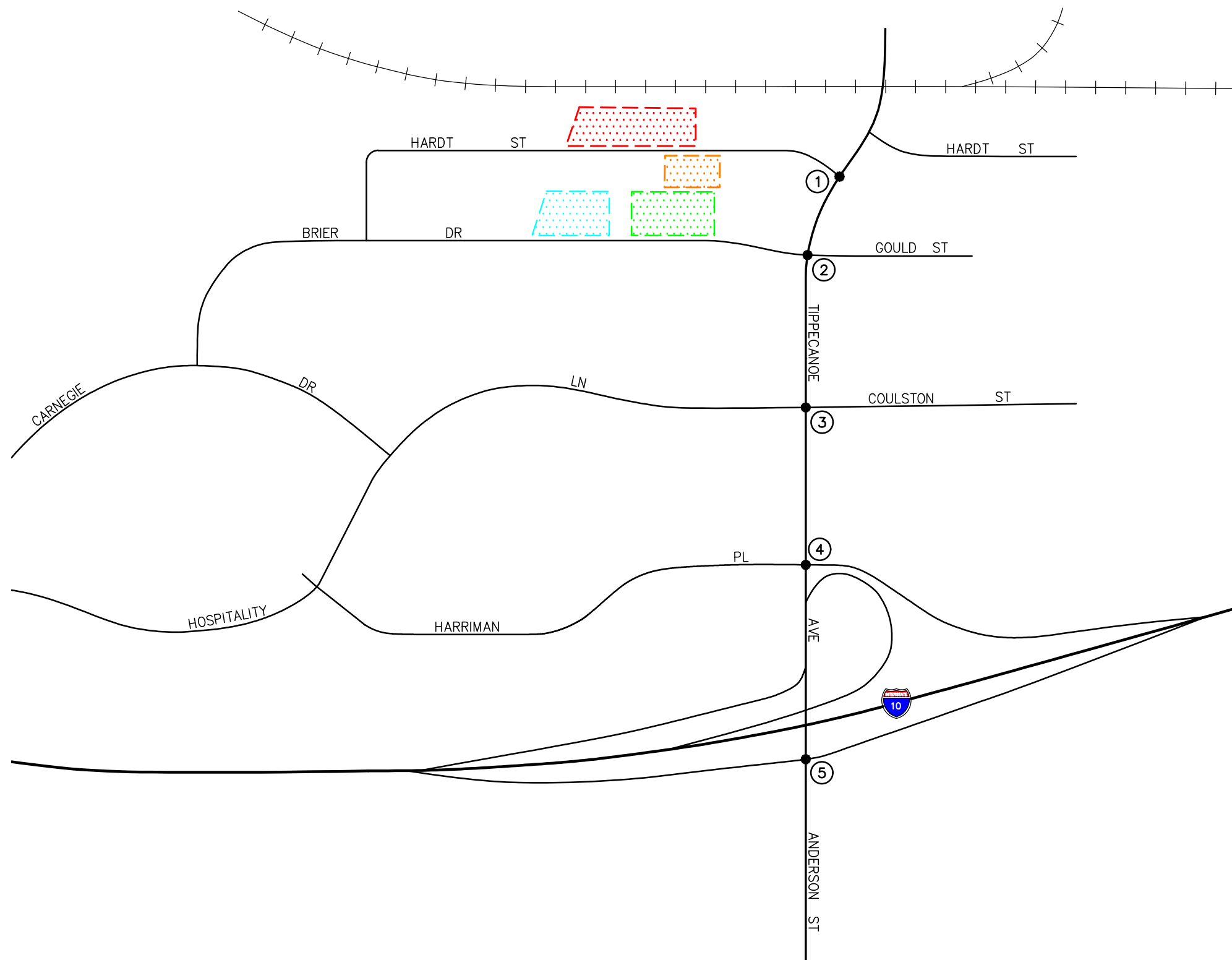
n:\4500\2214502 - hardt and brier business park project, san bernardino\dwg\4502 f6-6.dwg LDP 16:22:39 03-13-2023 kopulsky



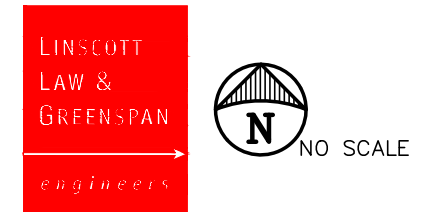
- KEY**
- # = STUDY INTERSECTION
  - + + = RAILROAD TRACKS
  - [Red Dotted Box] = BUILDINGS A & B
  - [Orange Dotted Box] = BUILDING C
  - [Green Dotted Box] = BUILDINGS D1 AND D2
  - [Cyan Dotted Box] = BUILDING E

**FIGURE 6-6**

**YEAR 2025 WITHOUT PROJECT AM PEAK HOUR TRAFFIC VOLUMES**  
HARDT AND BRIER BUSINESS PARK PROJECT, SAN BERNARDINO



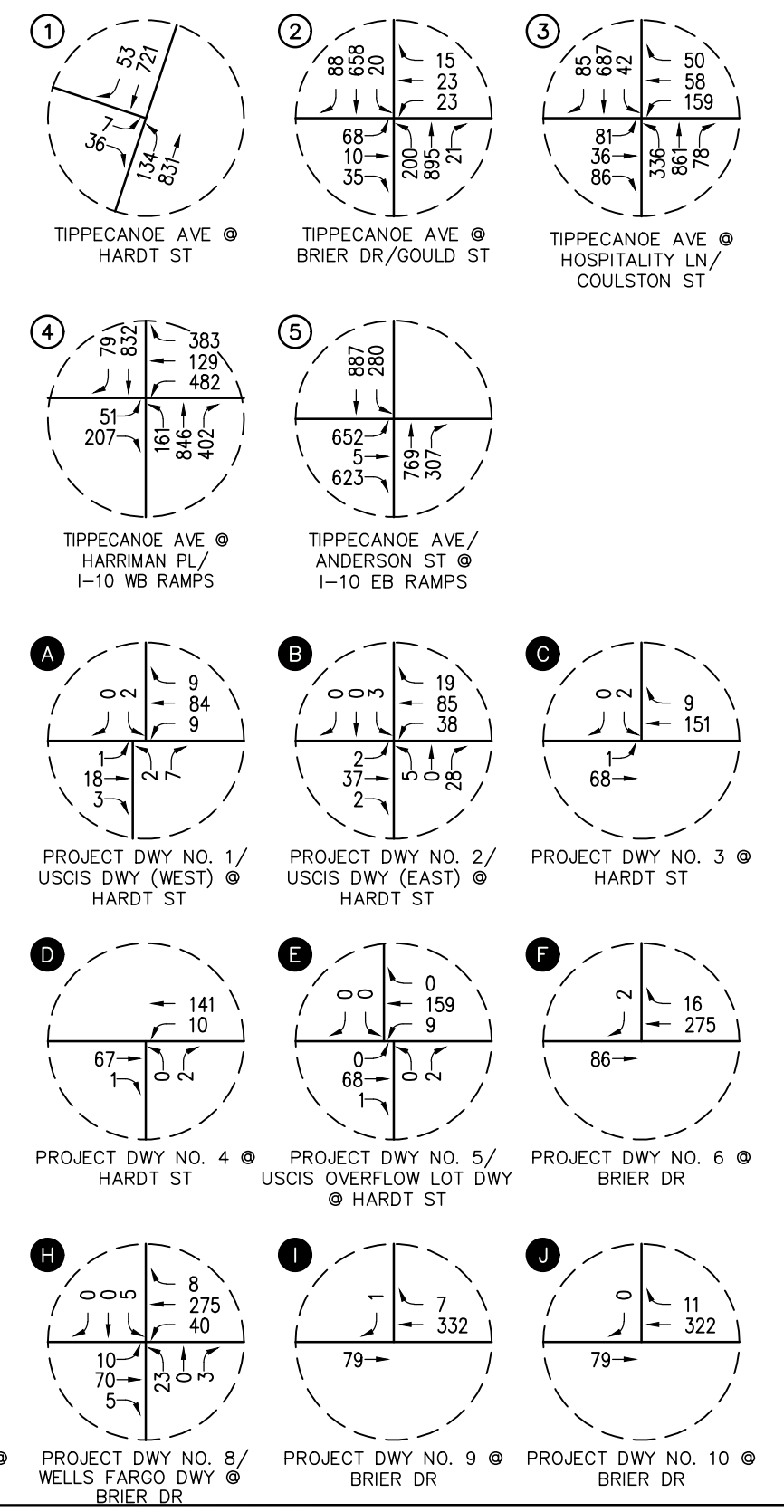
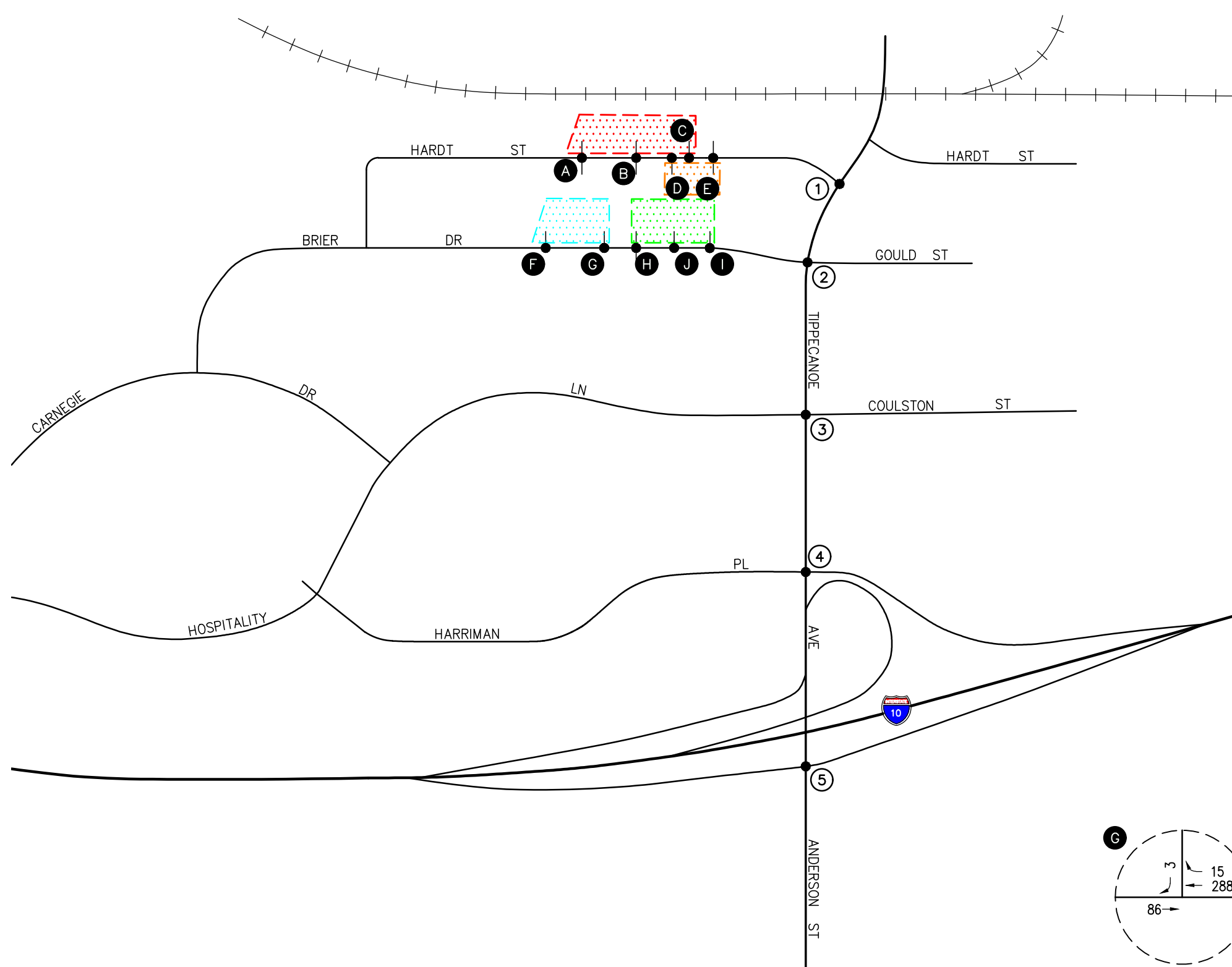
n:\4500\2214502 - hardt and brier business park project, san bernardino\dwg\4502 f6-7.dwg LDP 16:23:04 03-13-2023 kopulsky



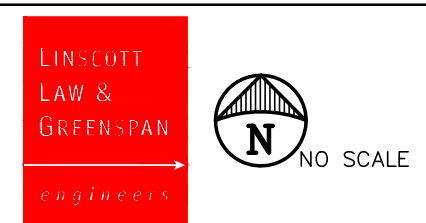
- KEY**
- # = STUDY INTERSECTION
  - + + = RAILROAD TRACKS
  - [Red Dotted Box] = BUILDINGS A & B
  - [Orange Dotted Box] = BUILDING C
  - [Green Dotted Box] = BUILDINGS D1 AND D2
  - [Cyan Dotted Box] = BUILDING E

**FIGURE 6-7**

**YEAR 2025 WITHOUT PROJECT PM PEAK HOUR TRAFFIC VOLUMES**  
HARDT AND BRIER BUSINESS PARK PROJECT, SAN BERNARDINO

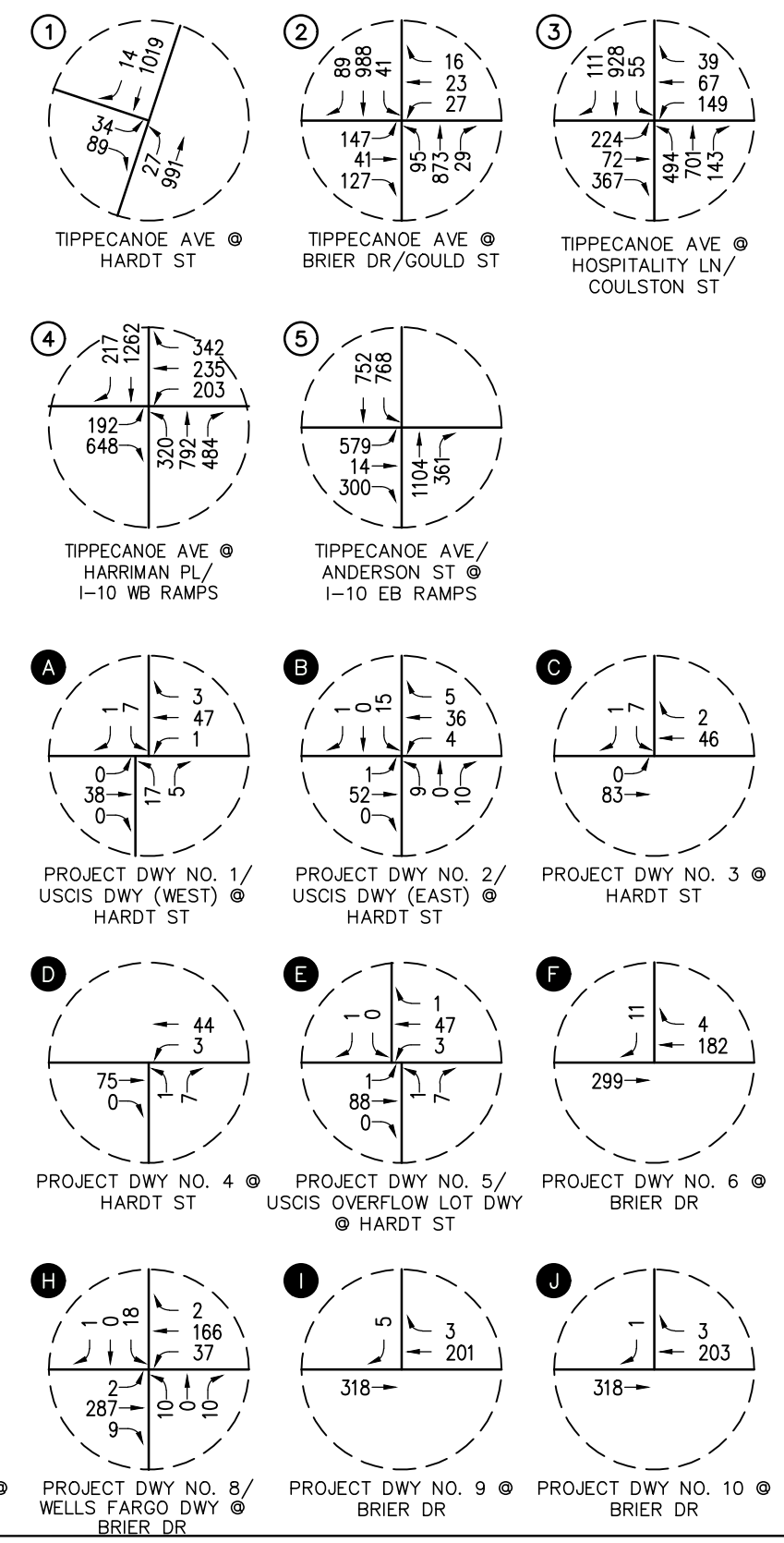
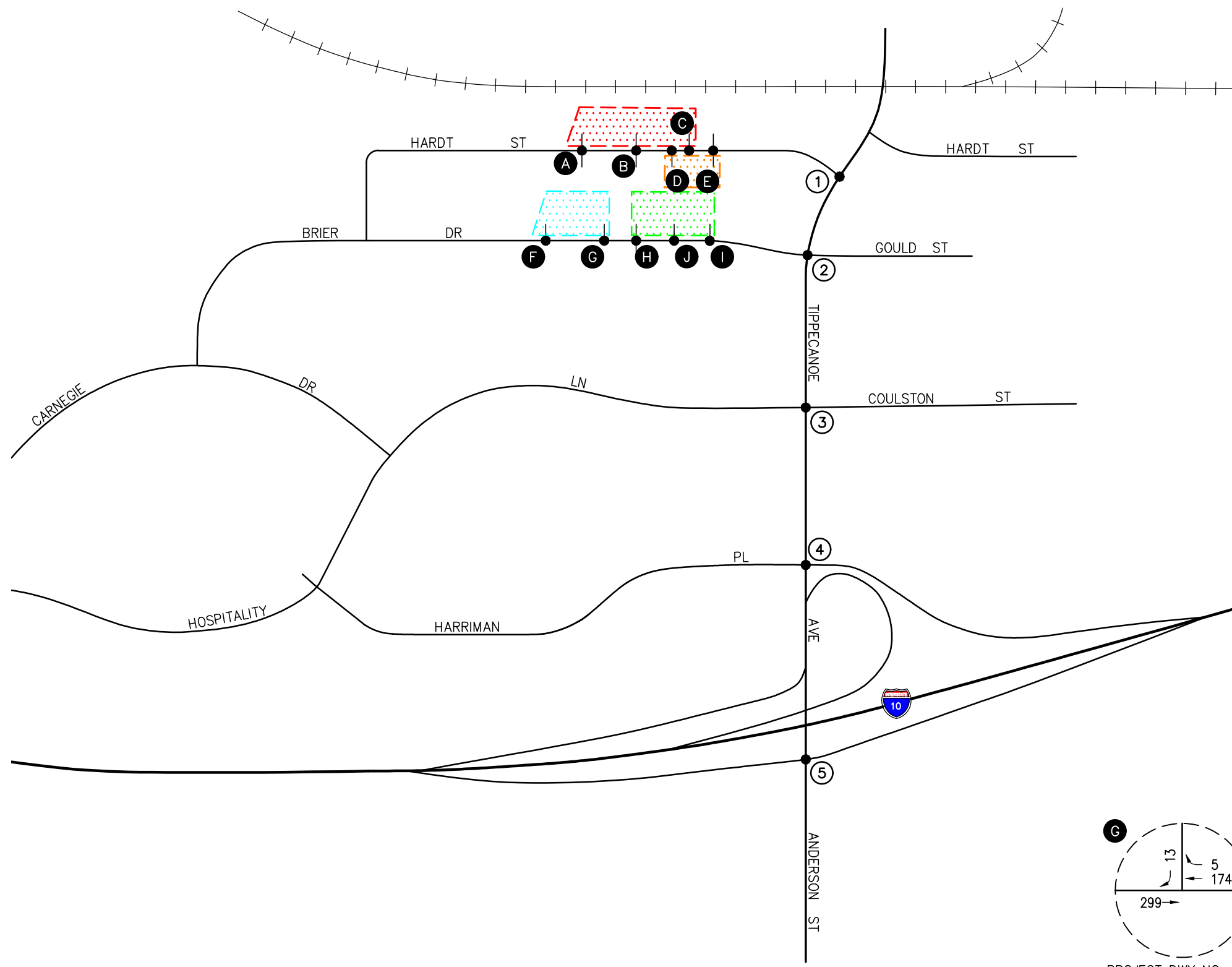


n:\4500\2214502 - hardt and brier business park project, san bernardino\dwg\4502 f6-8.dwg LDP 17:02:46 03-21-2023 kopulsky

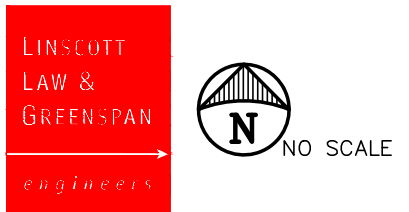


- KEY**
- # = STUDY INTERSECTION
  - + + = RAILROAD TRACKS
  - [Red Dotted Box] = BUILDINGS A & B
  - [Orange Dotted Box] = BUILDING C
  - [Green Dotted Box] = BUILDINGS D1 AND D2
  - [Blue Dotted Box] = BUILDING E

**FIGURE 6-8**  
**YEAR 2025 WITH PROJECT AM PEAK HOUR TRAFFIC VOLUMES**  
 HARDT AND BRIER BUSINESS PARK PROJECT, SAN BERNARDINO

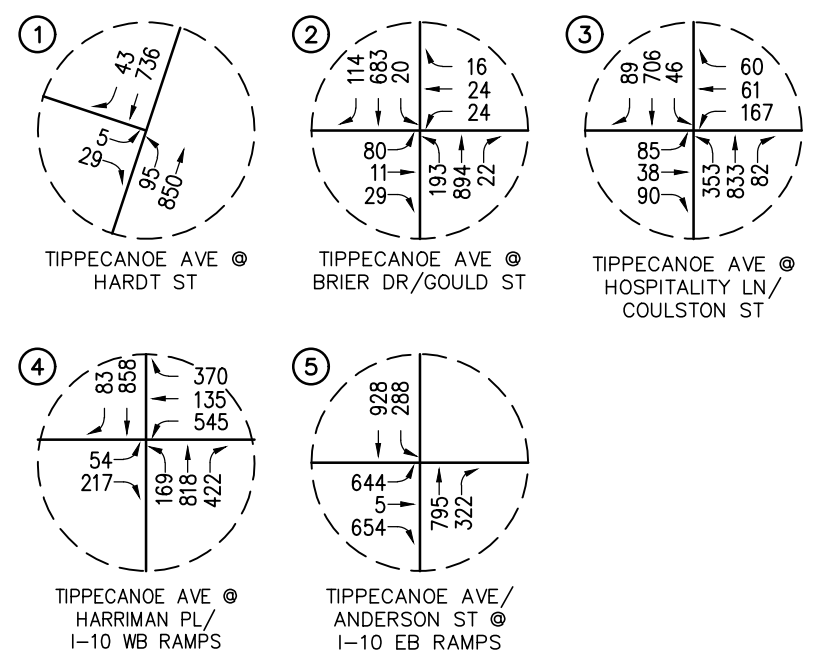
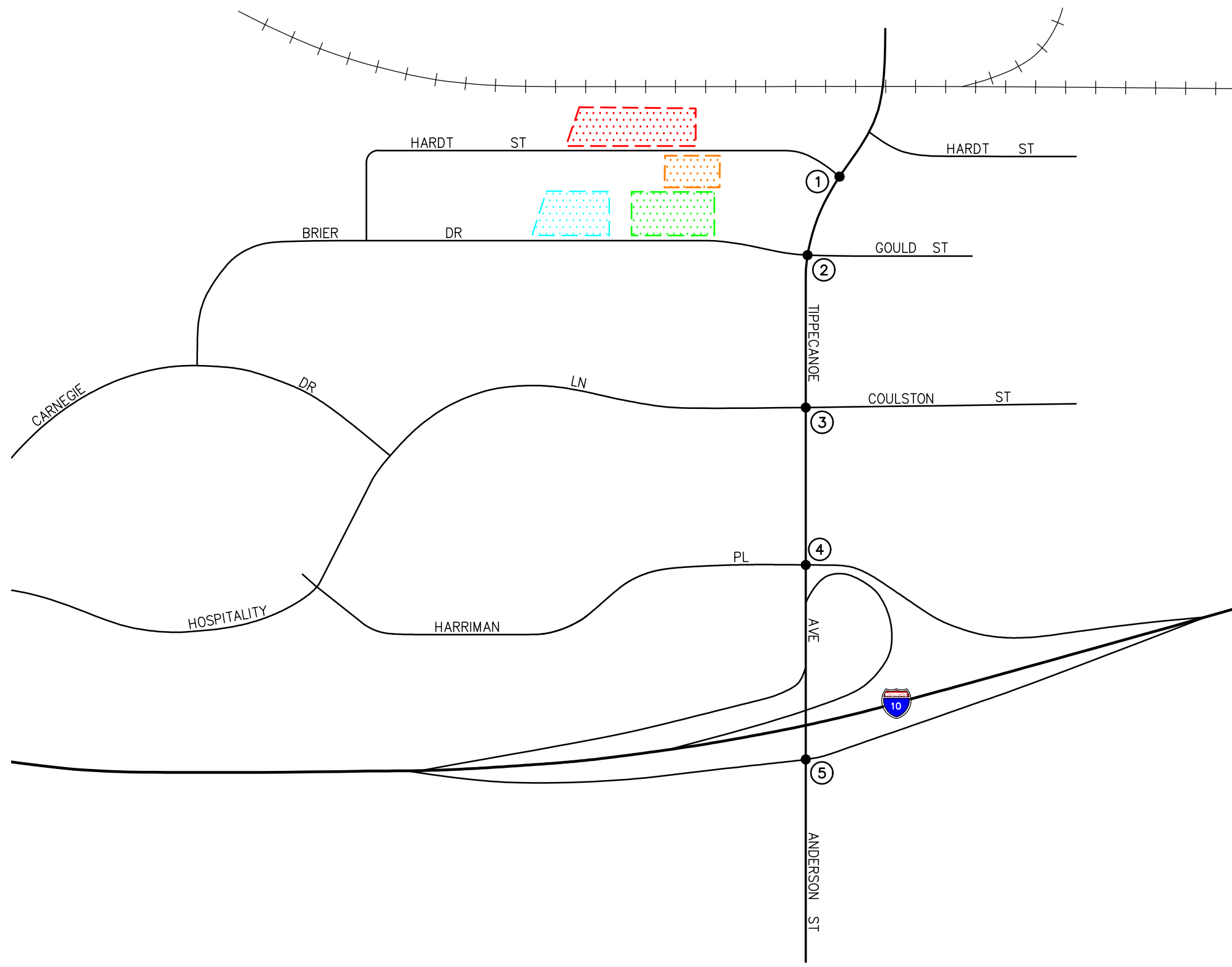


- KEY**
- # = STUDY INTERSECTION
  - + + = RAILROAD TRACKS
  - [Red Dotted Box] = BUILDINGS A & B
  - [Orange Dotted Box] = BUILDING C
  - [Green Dotted Box] = BUILDINGS D1 AND D2
  - [Blue Dotted Box] = BUILDING E

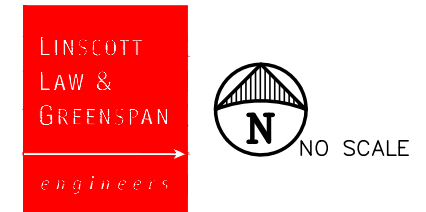


**FIGURE 6-9**

**YEAR 2025 WITH PROJECT PM PEAK HOUR TRAFFIC VOLUMES**  
HARDT AND BRIER BUSINESS PARK PROJECT, SAN BERNARDINO



n:\4500\2214502 - hardt and brier business park project, san bernardino\dwg\4502 f6-10.dwg LDP 13:13:30 03-09-2023 kopulsky

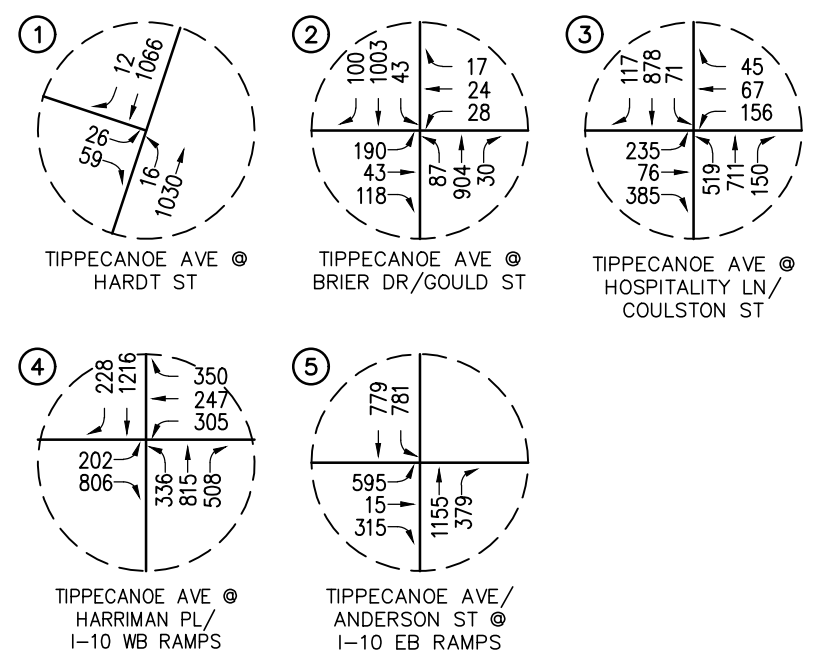
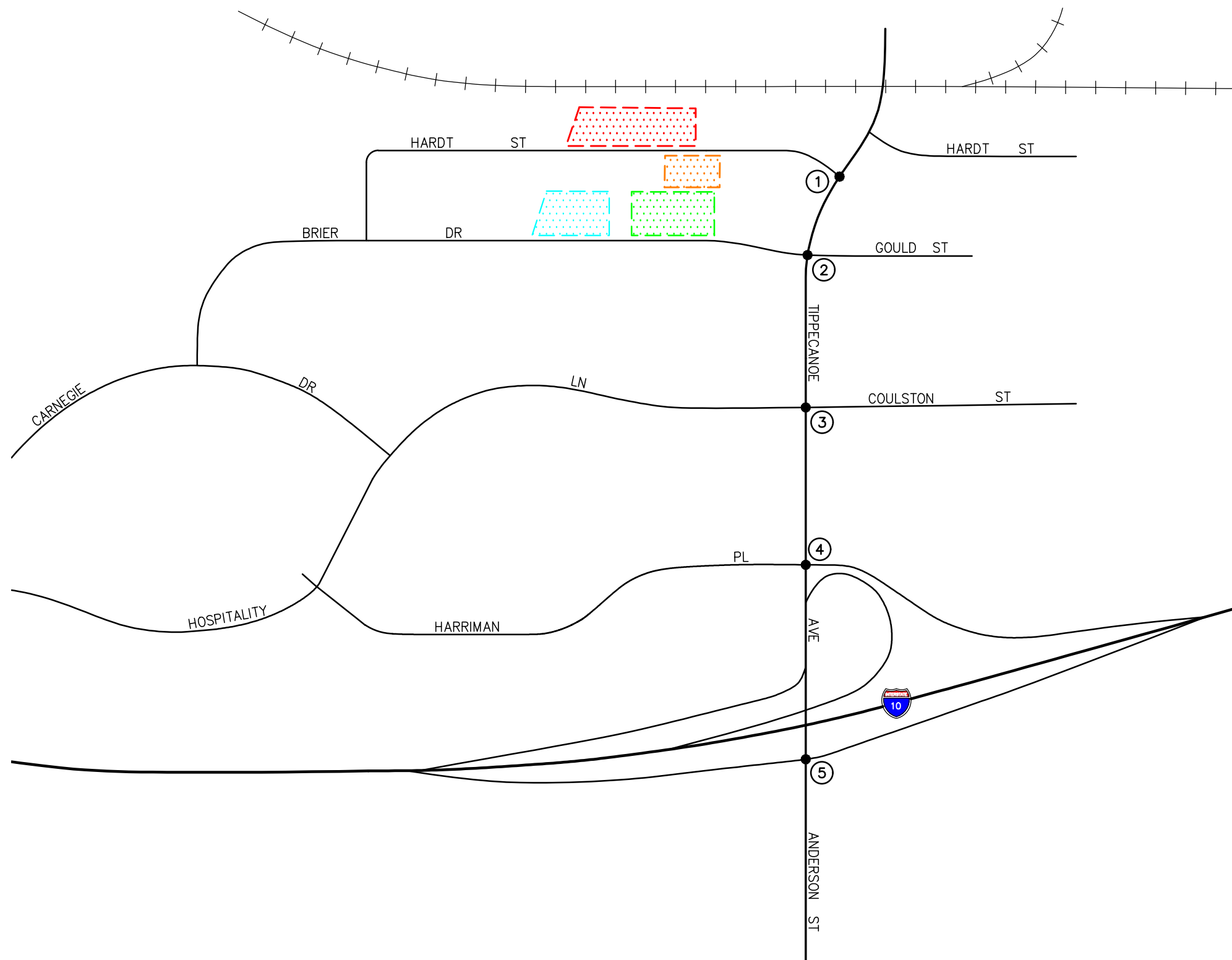


NO SCALE

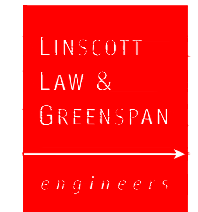
- KEY**
- # = STUDY INTERSECTION
  - + + = RAILROAD TRACKS
  - [Red Hatched Box] = BUILDINGS A & B
  - [Orange Hatched Box] = BUILDING C
  - [Green Hatched Box] = BUILDINGS D1 AND D2
  - [Cyan Hatched Box] = BUILDING E

**FIGURE 6-10**

**BUILDOUT WITHOUT PROJECT AM PEAK HOUR TRAFFIC VOLUMES**  
HARDT AND BRIER BUSINESS PARK PROJECT, SAN BERNARDINO



n:\4500\2214502 - hardt and brier business park project, san bernardino\dwg\4502 f6-11.dwg LDP 13:14:12 03-09-2023 kopulsky

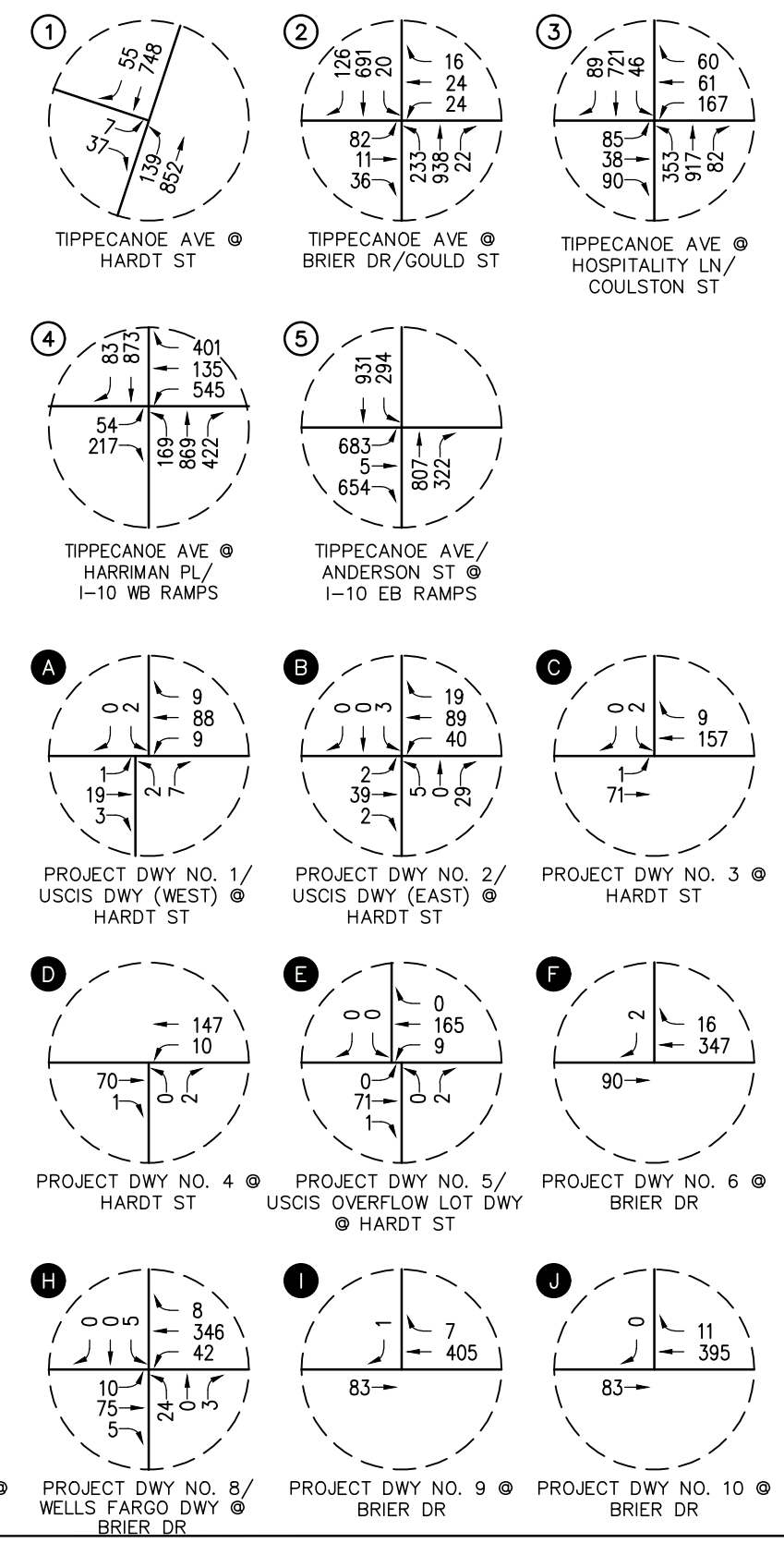
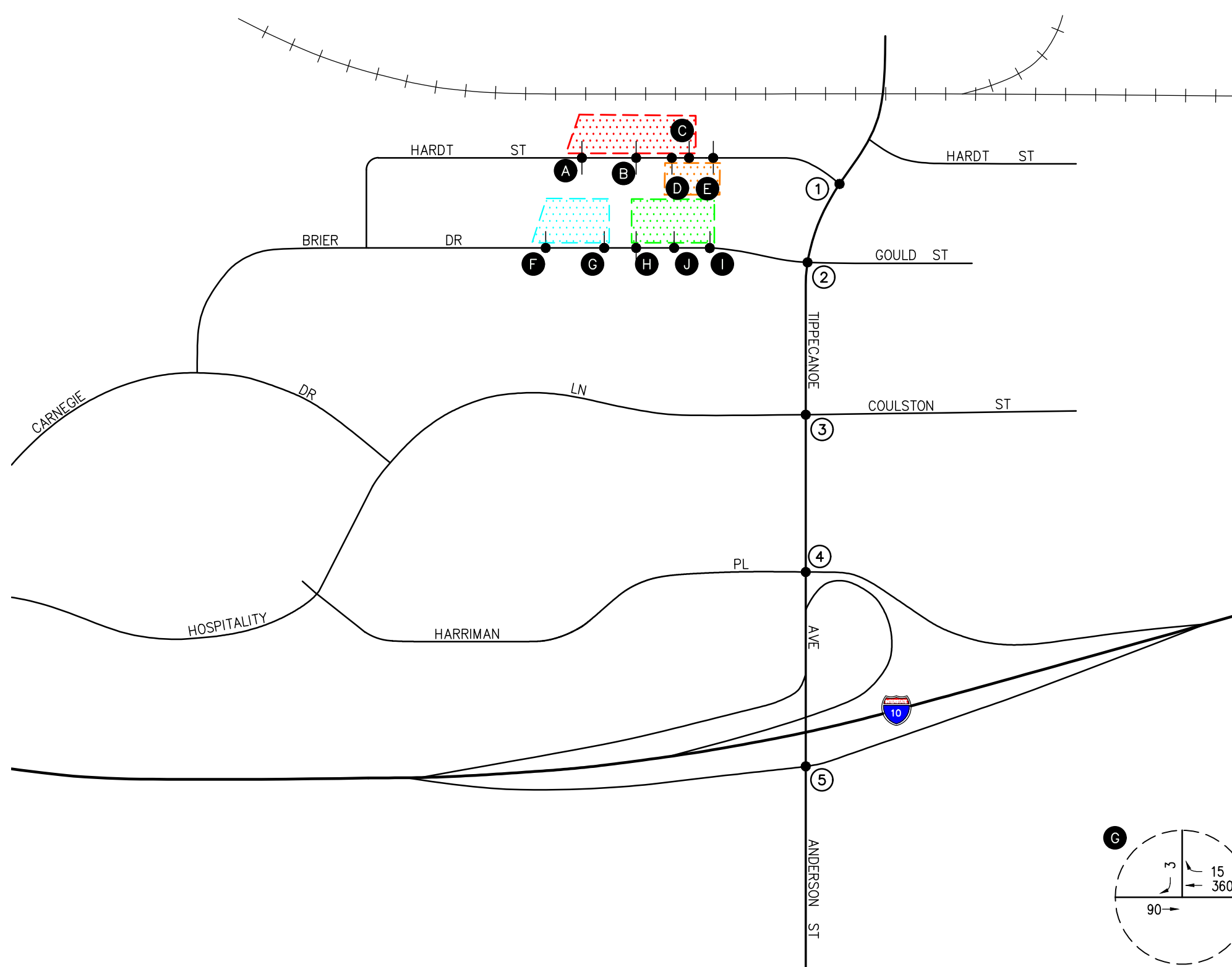


- KEY**
- # = STUDY INTERSECTION
  - + + = RAILROAD TRACKS
  - [Red Dotted Box] = BUILDINGS A & B
  - [Orange Dotted Box] = BUILDING C
  - [Green Dotted Box] = BUILDINGS D1 AND D2
  - [Blue Dotted Box] = BUILDING E

**FIGURE 6-11**

**BUILDOUT WITHOUT PROJECT PM PEAK HOUR TRAFFIC VOLUMES**  
HARDT AND BRIER BUSINESS PARK PROJECT, SAN BERNARDINO

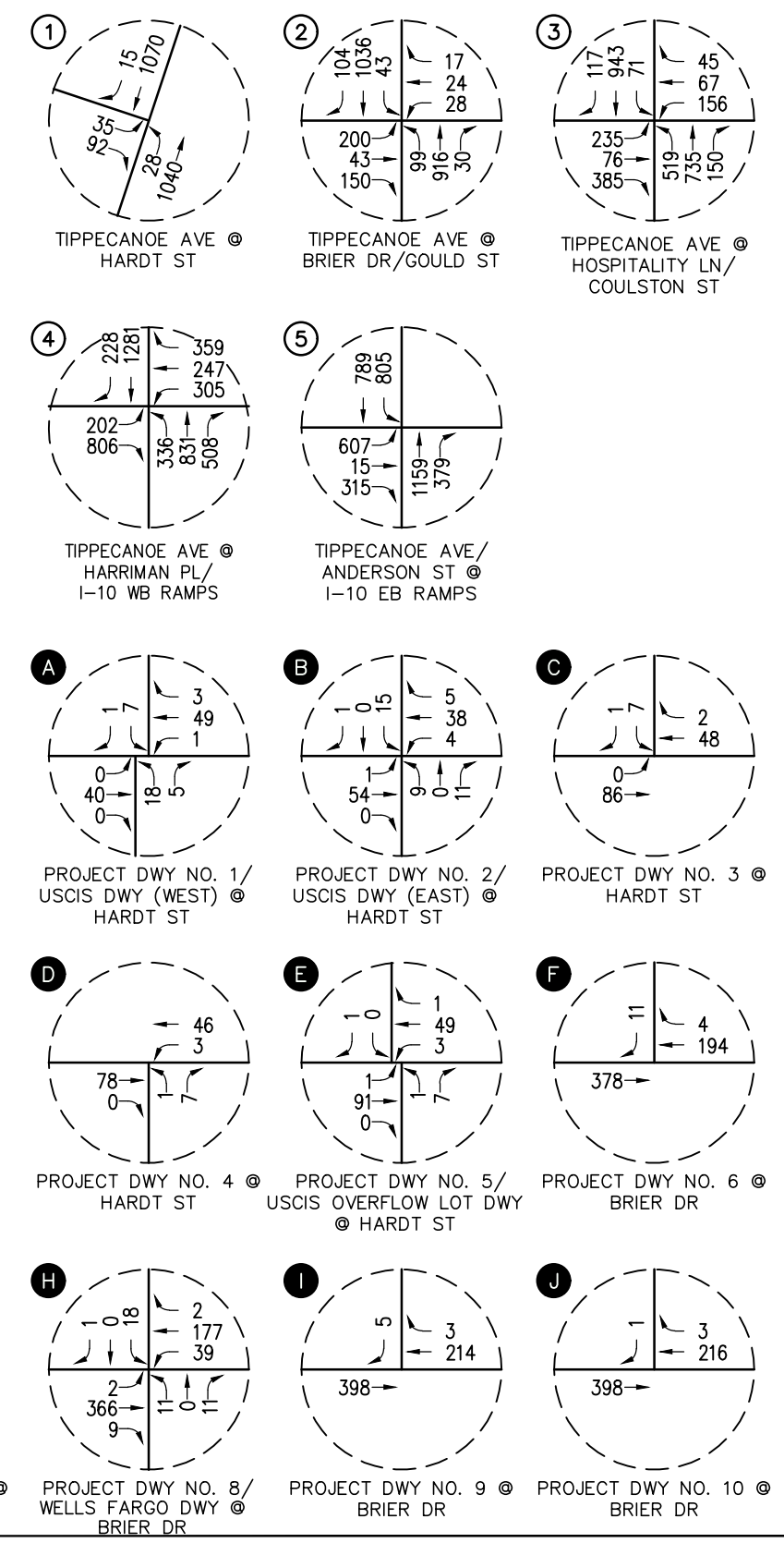
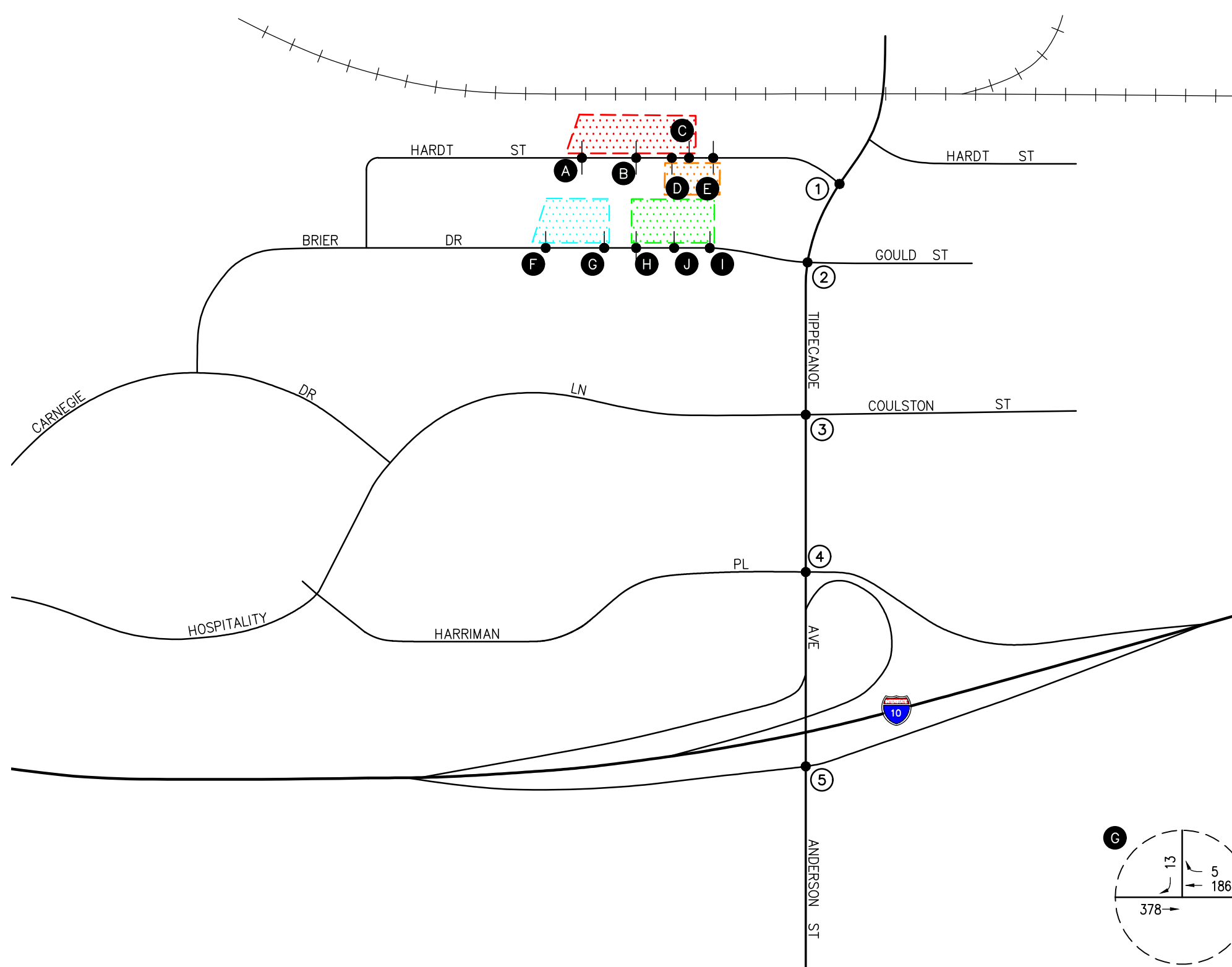




**KEY**

- # = STUDY INTERSECTION
- + + = RAILROAD TRACKS
- [Red Dotted Box] = BUILDINGS A & B
- [Orange Dotted Box] = BUILDING C
- [Green Dotted Box] = BUILDINGS D1 AND D2
- [Blue Dotted Box] = BUILDING E

**FIGURE 6-12**  
**BUILDOUT WITH PROJECT AM PEAK HOUR TRAFFIC VOLUMES**  
HARDT AND BRIER BUSINESS PARK PROJECT, SAN BERNARDINO



## 7.0 EXISTING WITH PROJECT ANALYSIS

*Table 7-1* summarizes the peak hour Level of Service results at the five (5) key study intersections for existing traffic conditions, without and with the proposed Project. The first column (1) of Delay/LOS values in *Table 7-1* presents a summary of Existing AM and PM peak hour traffic conditions. The second column (2) presents forecast Existing With Project traffic conditions. The third column (3) indicates whether the traffic associated with the Project will cause an operational deficiency based on the LOS criteria defined in this report. The fourth column (4) indicates the anticipated operating conditions with implementation of recommended improvements.

### 7.1 Existing Traffic Conditions

Review of column (1) of *Table 7-1* indicates that for Existing traffic conditions, all five (5) key study intersections currently operate at acceptable LOS C or better during the AM and PM peak hours when compared to the LOS standards defined in this report.

### 7.2 Existing With Project Traffic Conditions

Review of columns 2 and 3 of *Table 7-1* indicates that traffic associated with the proposed Project ***will not*** cause an operational deficiency at the five (5) key study intersections when compared to the LOS criteria defined in this report. The five (5) key study intersections currently operate and are forecast to continue to operate at an acceptable LOS during the AM and PM peak hours with the addition of Project generated traffic to existing traffic.

***Appendix D*** contains the Delay/LOS calculation worksheets for Existing and Existing With Project Traffic Conditions.

**TABLE 7-1**  
**EXISTING WITH PROJECT CONDITIONS PEAK HOUR INTERSECTION CAPACITY ANALYSIS SUMMARY**

Key Intersection	Jurisdiction	Minimum Acceptable LOS	Time Period	(1) Existing Traffic Conditions			(2) Existing With Project Traffic Conditions			(3) Operational Deficiency		(4) Existing With Project With Improvements		
				Delay	LOS	V/C	Delay	LOS	V/C	V/C or Delay Inc.	Yes/No	Delay	LOS	V/C
1. Tippecanoe Avenue at Hardt Street	San Bernardino	D	AM	13.2 s/v	B	--	14.5 s/v	B	--	--	No	--	--	--
			PM	16.8 s/v	C	--	19.0 s/v	C	--	--	No	--	--	--
2. Tippecanoe Avenue at Brier Drive/Gould Street	San Bernardino	D	AM	7.0 s/v	A	0.223	7.0 s/v	A	0.236	0.013	No	--	--	--
			PM	10.4 s/v	B	0.312	11.1 s/v	B	0.331	0.019	No	--	--	--
3. Tippecanoe Avenue at Hospitality Lane/Coulston Street	San Bernardino	D	AM	24.7 s/v	C	0.380	25.2 s/v	C	0.384	0.004	No	--	--	--
			PM	31.5 s/v	C	0.592	31.7 s/v	C	0.607	0.015	No	--	--	--
4. Tippecanoe Avenue at Harriman Place/I-10 WB Ramps	San Bernardino/ Caltrans	D	AM	26.8 s/v	C	0.368	26.7 s/v	C	0.370	0.002	No	--	--	--
			PM	29.8 s/v	C	0.590	29.9 s/v	C	0.604	0.014	No	--	--	--
5. Tippecanoe Avenue/Anderson St at I-10 EB Ramps	Loma Linda/ Caltrans	D	AM	21.2 s/v	C	--	21.3 s/v	C	--	0.1 s/v	No	--	--	--
			PM	23.9 s/v	C	--	24.2 s/v	C	--	0.3 s/v	No	--	--	--

**Notes:**

- s/v = seconds per vehicle (delay)
- LOS = Level of Service
- **Bold Delay/LOS values** indicate adverse service levels based on the LOS standards as defined in this report

## 8.0 YEAR 2025 WITH PROJECT ANALYSIS

*Table 8-1* summarizes the AM and PM peak hour Level of Service results at the five (5) key study intersections for Year 2025 traffic conditions. The first column (1) of Delay/LOS values in *Table 8-1* presents a summary of existing AM and PM peak hour traffic conditions (which were also presented in *Table 7-1*). The second column (2) presents forecast Year 2025 Without Project traffic conditions and the third column (3) identifies forecast Year 2025 With Project traffic conditions. The fourth column (4) indicates whether the traffic associated with the Project will cause an operational deficiency based on the LOS criteria defined in this report. The fifth column (5) indicates the anticipated operating conditions with implementation of recommended improvements.

### 8.1 Year 2025 Without Project Traffic Conditions

An analysis of future (Year 2025) cumulative traffic conditions indicates that the addition of ambient traffic growth and cumulative projects traffic will not adversely impact the five (5) key study intersections. The five (5) key study intersections are forecast to continue to operate at acceptable levels of service during the AM and PM peak hours with the addition of ambient traffic growth and cumulative projects traffic.

### 8.2 Year 2025 With Project Traffic Conditions

Review of columns 3 and 4 of *Table 8-1* indicates that traffic associated with the proposed Project will not cause an operational deficiency at the five (5) key study intersections when compared to the LOS criteria defined in this report. The five (5) key study intersections are forecast to continue to operate at an acceptable LOS D or better during the AM and PM peak hours with the addition of Project generated traffic in the horizon Year 2025.

*Appendix E* contains the Delay/LOS calculation worksheets for Year 2025 Traffic Conditions and Year 2025 With Project Traffic Conditions.

**TABLE 8-1**  
**YEAR 2025 WITH PROJECT CONDITIONS PEAK HOUR INTERSECTION CAPACITY ANALYSIS SUMMARY**

Key Intersection	Jurisdiction	Min. Acc. LOS	Time Period	(1) Existing Traffic Conditions			(2) Year 2025 Without Project Traffic Conditions			(3) Year 2025 With Project Traffic Conditions			(4) Operational Deficiency		(5) Year 2025 With Project With Improvements		
				Delay	LOS	V/C	Delay	LOS	V/C	Delay	LOS	V/C	V/C or Delay Inc.	Yes/No	Delay	LOS	V/C
1. Tippecanoe Avenue at Hardt Street	San Bernardino	D	AM	13.2 s/v	B	--	17.1 s/v	C	--	20.5 s/v	C	--	--	No	--	--	--
			PM	16.8 s/v	C	--	24.7 s/v	C	--	31.4 s/v	D	--	--	No	--	--	--
2. Tippecanoe Avenue at Brier Drive/Gould Street	San Bernardino	D	AM	7.0 s/v	A	0.223	6.9 s/v	A	0.299	6.9 s/v	A	0.313	0.014	No	--	--	--
			PM	10.4 s/v	B	0.312	10.4 s/v	B	0.395	11.0 s/v	B	0.414	0.019	No	--	--	--
3. Tippecanoe Avenue at Hospitality Lane/Coulston St	San Bernardino	D	AM	24.7 s/v	C	0.380	25.2 s/v	C	0.498	25.6 s/v	C	0.498	0.000	No	--	--	--
			PM	31.5 s/v	C	0.592	33.3 s/v	C	0.716	33.3 s/v	C	0.730	0.014	No	--	--	--
4. Tippecanoe Avenue at Harriman Place/I-10 WB Ramps	San Bernardino / Caltrans	D	AM	26.8 s/v	C	0.368	26.2 s/v	C	0.451	26.3 s/v	C	0.453	0.002	No	--	--	--
			PM	29.8 s/v	C	0.590	31.6 s/v	C	0.703	31.6 s/v	C	0.716	0.013	No	--	--	--
5. Tippecanoe Avenue/Anderson St at I-10 EB Ramps	Loma Linda / Caltrans	D	AM	21.2 s/v	C	--	22.1 s/v	C	--	22.4 s/v	C	--	0.3 s/v	No	--	--	--
			PM	23.9 s/v	C	--	28.2 s/v	C	--	29.1 s/v	C	--	0.9 s/v	No	--	--	--

**Notes:**

- s/v = seconds per vehicle (delay)
- LOS = Level of Service
- **Bold Delay/LOS values** indicate adverse service levels based on the LOS standards as defined in this report

## 9.0 BUILDOUT WITH PROJECT ANALYSIS

*Table 9-1* summarizes the AM and PM peak hour Level of Service results at the five (5) key study intersections for Buildout traffic conditions. The first column (1) of Delay/LOS values in *Table 9-1* presents a summary of existing AM and PM peak hour traffic conditions (which were also presented in *Tables 7-1* and *8-1*). The second column (2) presents forecast Buildout Without Project traffic conditions and the third column (3) identifies forecast Buildout With Project traffic conditions. The fourth column (4) indicates whether the traffic associated with the Project will cause an operational deficiency based on the LOS criteria defined in this report. The fifth column (5) indicates the anticipated operating conditions with implementation of recommended improvements.

### 9.1 Buildout Without Project Traffic Conditions

Review of column (2) of *Table 9-1* indicates that for Buildout Without Project traffic conditions, all five (5) key study intersections are forecast to continue to operate at acceptable levels of service during the AM and PM peak hours.

### 9.2 Buildout With Project Traffic Conditions

Review of columns 3 and 4 of *Table 9-1* indicates that traffic associated with the proposed Project ***will not*** cause an operational deficiency at the five (5) key study intersections when compared to the LOS criteria defined in this report. The five (5) key study intersections are forecast to continue to operate at an acceptable LOS D or better during the AM and PM peak hours with the addition of Project generated traffic added to Buildout traffic conditions.

*Appendix F* contains the Delay/LOS calculation worksheets for Buildout Traffic Conditions and Buildout With Project Traffic Conditions.

**TABLE 9-1**  
**BUILDOUT WITH PROJECT CONDITIONS PEAK HOUR INTERSECTION CAPACITY ANALYSIS SUMMARY**

Key Intersection	Jurisdiction	Min. Acc. LOS	Time Period	(1) Existing Traffic Conditions			(2) Buildout Without Project Traffic Conditions			(3) Buildout With Project Traffic Conditions			(4) Operational Deficiency		(5) Buildout With Project With Improvements		
				Delay	LOS	V/C	Delay	LOS	V/C	Delay	LOS	V/C	V/C or Delay Inc.	Yes/No	Delay	LOS	V/C
1. Tippecanoe Avenue at Hardt Street	San Bernardino	D	AM	13.2 s/v	B	--	15.2 s/v	C	--	17.3 s/v	C	--	--	No	--	--	--
			PM	16.8 s/v	C	--	25.7 s/v	D	--	33.1 s/v	D	--	--	No	--	--	--
2. Tippecanoe Avenue at Brier Drive/Gould Street	San Bernardino	D	AM	7.0 s/v	A	0.223	6.8 s/v	A	0.265	6.8 s/v	A	0.278	0.013	No	--	--	--
			PM	10.4 s/v	B	0.312	11.5 s/v	B	0.412	12.0 s/v	B	0.430	0.018	No	--	--	--
3. Tippecanoe Avenue at Hospitality Lane/Coulston St	San Bernardino	D	AM	24.7 s/v	C	0.380	25.4 s/v	C	0.464	28.0 s/v	C	0.473	0.009	No	--	--	--
			PM	31.5 s/v	C	0.592	31.9 s/v	C	0.696	34.7 s/v	C	0.719	0.023	No	--	--	--
4. Tippecanoe Avenue at Harriman Place/I-10 WB Ramps	San Bernardino / Caltrans	D	AM	26.8 s/v	C	0.368	26.3 s/v	C	0.456	26.3 s/v	C	0.458	0.002	No	--	--	--
			PM	29.8 s/v	C	0.590	32.2 s/v	C	0.740	32.2 s/v	C	0.752	0.012	No	--	--	--
5. Tippecanoe Avenue/Anderson St at I-10 EB Ramps	Loma Linda / Caltrans	D	AM	21.2 s/v	C	--	22.7 s/v	C	--	23.6 s/v	C	--	0.9 s/v	No	--	--	--
			PM	23.9 s/v	C	--	28.3 s/v	C	--	29.2 s/v	C	--	0.9 s/v	No	--	--	--

**Notes:**

- s/v = seconds per vehicle (delay)
- LOS = Level of Service
- **Bold Delay/LOS values** indicate adverse service levels based on the LOS standards as defined in this report



## 10.0 SITE ACCESS AND INTERNAL CIRCULATION EVALUATION

### 10.1 Site Access

As shown previously on *Figure 2-2*, vehicular access to Buildings A, B and C will be provided via unsignalized driveways located along Hardt Street (referred to as Project Driveways No. 1, No. 2, No. 3, No. 4 and No. 5). Project Driveways No. 1, No. 2, No. 3, No. 4 and No. 5 will all be full access driveways. Vehicular access to Buildings D1, D2 and E will be provided via unsignalized driveways located along Brier Drive (referred to as Project Driveways No. 6, No. 7, No. 8, No. 9 and No. 10). Project Driveway No. 8 will be a full access driveway. Project Driveways No. 6, No. 7, No. 9 and No. 10 will be right-turn in/right-turn out only access driveways.

**Table 10-1** summarizes the intersection operations at the proposed Project driveways for near-term (Year 2025) and Buildout traffic conditions at completion and full occupancy of the proposed Project. The operations analysis for the Project driveways is based on the *Highway Capacity Manual 7<sup>th</sup> Edition* (HCM 7) unsignalized methodology. Review of **Table 10-1** shows that the ten (10) Project driveways are forecast to operate at acceptable LOS B or better during the AM and PM peak hours for Year 2025 With Project traffic conditions and Buildout With Project traffic conditions. As such, project access will be adequate.

**Appendix G** contains the Delay/LOS calculation worksheets for the project driveways for Year 2025 With Project Traffic Conditions and Buildout With Project Traffic Conditions.

### 10.2 Internal Circulation Evaluation

The on-site circulation layout of the proposed Project as illustrated in *Figure 2-2* on an overall basis is adequate. Curb return radii have been confirmed and are generally adequate for small and large service/delivery (FedEx, UPS, tractor-trailers) trucks.

**TABLE 10-1**  
**PROJECT DRIVEWAY PEAK HOUR LEVELS OF SERVICE SUMMARY**

Key Intersection	Time Period	Intersection Control	Year 2025 With Project Traffic Conditions		Buildout With Project Traffic Conditions	
			Delay	LOS	Delay	LOS
A. Project Driveway No. 1/USCIS Driveway (West) at Hardt Street	AM	Two-Way	9.4 s/v	A	9.4 s/v	A
	PM	Stop	9.1 s/v	A	9.1 s/v	A
B. Project Driveway No. 2/USCIS Driveway (East) at Hardt Street	AM	Two-Way	10.3 s/v	B	10.5 s/v	B
	PM	Stop	9.3 s/v	A	9.3 s/v	A
C. Project Driveway No. 3 at Hardt Street	AM	One-Way	9.8 s/v	A	9.9 s/v	A
	PM	Stop	9.2 s/v	A	9.2 s/v	A
D. Project Driveway No. 4 at Hardt Street	AM	One-Way	8.6 s/v	A	8.7 s/v	A
	PM	Stop	8.8 s/v	A	8.8 s/v	A
E. Project Driveway No. 5/USCIS Overflow Lot Driveway at Hardt Street	AM	Two-Way	10.0 s/v	A	10.0 s/v	A
	PM	Stop	8.9 s/v	A	8.9 s/v	A
F. Project Driveway No. 6 at Brier Drive	AM	One-Way	9.2 s/v	A	9.4 s/v	A
	PM	Stop	8.9 s/v	A	8.9 s/v	A
G. Project Driveway No. 7 at Brier Drive	AM	One-Way	9.2 s/v	A	9.5 s/v	A
	PM	Stop	8.9 s/v	A	8.9 s/v	A
H. Project Driveway No. 8/Wells Fargo Driveway at Brier Drive	AM	Two-Way	12.5 s/v	B	13.6 s/v	B
	PM	Stop	12.3 s/v	B	13.0 s/v	B
I. Project Driveway No. 9 at Brier Drive	AM	One-Way	9.3 s/v	A	9.6 s/v	A
	PM	Stop	8.9 s/v	A	9.0 s/v	A
J. Project Driveway No. 10 at Brier Drive	AM	One-Way	9.3 s/v	A	9.6 s/v	A
	PM	Stop	8.9 s/v	A	8.9 s/v	A

**Notes:**

s/v = seconds per vehicle

## 11.0 CALTRANS FACILITIES ANALYSIS

Caltrans requires the use of analysis methods provided in the Highway Capacity Manual 7 (*HCM 7*) for the analysis of ramp intersections. Caltrans “endeavors to maintain a target LOS at the transition between LOS “C” and LOS “D” on State highway facilities”; it does not require that LOS “D” (shall) be maintained. However, Caltrans acknowledges that this may not always be feasible and recommends that the lead agency consult with Caltrans to determine the appropriate target LOS. For this analysis, LOS D is the target level of service standard and will be utilized to assess the Project impacts at the state-controlled study intersections.

Ramp Intersection Capacity Analyses were conducted for the following two (2) state-controlled key study intersections:

4. Tippecanoe Avenue at Harriman Place/I-10 Westbound Ramps
5. Tippecanoe Avenue/Anderson Street at I-10 Eastbound Ramps

### 11.1 Ramp Intersection Capacity Analysis

As shown in *Tables 7-1, 8-1* and *9-1*, presented previously in Sections 7.0, 8.0 and 9.0, the two (2) state-controlled study intersections are forecast to operate at an acceptable LOS D or better during the AM peak hour and PM peak hour without and with the proposed Project for all analyzed traffic conditions.

## 12.0 RECOMMENDED IMPROVEMENTS

For those intersections where projected traffic volumes are expected to result in deficiencies, this report recommends traffic improvements that change the intersection geometry to increase capacity. These capacity improvements involve roadway widening and/or re-striping to reconfigure (add lanes) roadways to specific approaches of a key intersection. The identified improvements are expected to:

- Address the impact of existing traffic, Project traffic and future non-project (ambient traffic growth and cumulative) traffic, and
- Improve Levels of Service to an acceptable range and/or to pre-project conditions.

### 12.1 Existing With Project Traffic Conditions

The results of the Existing With Project traffic conditions level of service analyses indicate that the proposed Project ***will not*** impact any of the five (5) key study intersections. All five (5) key study intersections are forecast to operate at acceptable service levels under Existing With Project traffic conditions. As such, no improvement measures have been recommended.

### 12.2 Year 2025 With Project Traffic Conditions

The results of the Year 2025 With Project traffic conditions level of service analyses indicate that the proposed Project ***will not*** impact any of the five (5) key study intersections. All five (5) key study intersections are forecast to operate at acceptable service levels under Year 2025 With Project traffic conditions. As such, no improvement measures have been recommended.

### 12.3 Buildout With Project Traffic Conditions

The results of the Buildout With Project traffic conditions level of service analyses indicate that the proposed Project ***will not*** impact any of the five (5) key study intersections. All five (5) key study intersections are forecast to operate at acceptable service levels under Buildout With Project traffic conditions. As such, no improvement measures have been recommended.

## 13.0 VEHICLE MILES TRAVELED (VMT) ANALYSIS

On December 28, 2018, the California Natural Resources Agency adopted revised CEQA Guidelines. Among the changes to the guidelines was the removal of vehicle delay and LOS from consideration for transportation impacts under CEQA. With the adopted guidelines, transportation impacts are to be evaluated based on a project's effect on vehicle miles traveled. Lead agencies are allowed to continue using their current impact criteria, or to opt into the revised transportation guidelines. However, the new guidelines must be used starting July 1, 2020, as required in CEQA section 15064.3. The City of San Bernardino recently adopted new traffic impact criteria in August 2020 to be consistent with the CEQA revisions. These new guidelines are contained within the *City of San Bernardino Traffic Impact Analysis Guidelines*, dated August 2020 and provide screening criteria and methodology for VMT analysis.

Per the *City of San Bernardino Traffic Impact Analysis Guidelines*, there are three types of screening to screen projects from project-level VMT assessments. The three screening steps are described below. The results of each screening step applied to the proposed Project is also discussed. It should be noted that the project only needs to satisfy one of the three screening steps.

### Step 1: Transit Priority Area (TPA) Screening

Projects located within a transit priority area (TPA) may be presumed to have a less than significant impact absent substantial evidence to the contrary. This presumption may **NOT** be appropriate if the project:

1. Has a Floor Area Ratio (FAR) of less than 0.75;
2. Includes more parking for use by residents, customers, or employees of the project than required by the City (if the City requires the project to supply parking);
3. Is inconsistent with the applicable Sustainable Communities Strategy (as determined by the lead agency, with input from the Metropolitan Planning Organization); or
4. Replaces affordable residential units with a smaller number of moderate- or high-income residential units.

➤ *Based on the SBCTA screening tool, the project site is located within a Transit Priority Area (TPA). Although the proposed Project has a Floor Area Ratio (FAR) less than 0.75, the Project is a large development with many employees (i.e. approximately 150-250 employees amongst the six buildings) that would likely utilize transit and significantly benefit from being located within a TPA from a VMT reduction standpoint. Whereas a smaller project with a low FAR and a limited number of employees or population may not take advantage of the TPA. The proposed Project will provide a total of 280 parking spaces amongst the six buildings, which is less than City-code parking requirements. The proposed Project is consistent with the Sustainable Communities Strategy and does not replace affordable housing. Consequently, the proposed Project satisfies all four of the TPA criteria. As a result, based on the Step 1: Transit Priority Area (TPA) Screening criteria, this project could be screened from a VMT analysis, and could be presumed to have a less than significant impact on VMT per the City's guidelines.*

### Step 2: Low VMT Area Screening

Residential and office projects located within a low VMT-generating area may be presumed to have a less than significant impact absent substantial evidence to the contrary. In addition, other employment-related and mixed-use land use projects may qualify for the use of screening if the project can reasonably be expected to generate VMT per resident, per worker, or per service population that is similar to the existing land uses in the low VMT area. A low VMT area is defined as an individual traffic analysis zone (TAZ) where total daily Origin/Destination VMT per service population is lower than the City average total daily Origin/Destination VMT per service population.

- *Based on the SBCTA screening tool, the project site (all six proposed buildings) is located within Traffic Analysis Zone (TAZ) #53807502. Per the SBCTA screening tool (Baseline Year 2016), the Project TAZ VMT/service population is 71.8 VMT per service population and the City average VMT/service population is 29.6 VMT per service population. Comparison of the two VMT values indicates that the Project TAZ VMT is higher than the City VMT average. Therefore, Project Screening Step 2: Low VMT Area Screening is not satisfied.*

**Appendix H** contains the SBCTA VMT Screening Tool Data.

### Step 3: Project Type Screening

Local serving retail projects (including restaurants) less than 50,000 square feet may be presumed to have a less than significant impact absent substantial evidence to the contrary. Local serving retail generally improves the convenience of shopping close to home and has the effect of reducing vehicle travel. In addition to local serving retail, the following uses may, at the discretion of the City, be presumed to have a less than significant impact as their uses are often local serving in nature:

- Local parks
- Day care centers
- Local-serving retail uses less than 50,000 square feet, including:
  - Gas stations
  - Banks
  - Restaurants
  - Shopping Center
- Student housing projects on or adjacent to college campuses
- Local-serving assembly uses (places of worship, community organizations)
- Community institutions (Public libraries, fire stations, local government)
- Local serving community colleges that are consistent with the assumptions noted in the RTP/SCS
- Hotels (non-destination or resort; no banquet or special event space)
- Affordable or supportive housing
- Assisted living facilities
- Senior housing (as defined by HUD)

- Projects generating less than 110 daily vehicle trips. This generally corresponds to the following “typical” development potentials:
  - 11 single family housing units
  - 16 multi-family, condominiums, or townhouse housing units
  - 10,000 sq. ft. of office
  - 15,000 sq. ft. of light industrial
  - 63,000 sq. ft. of warehousing
  - 79,000 sq. ft. of high cube transload and short-term storage warehouse
- *As stated previously, the proposed Project will consist of a business park totaling a maximum of 108,500 SF and is forecast to generate approximately 1,350 daily trips, which are both greater than the aforementioned development size and daily trip thresholds. Therefore, Project Screening Step 3: Project Type Screening is not satisfied.*

### **13.1 VMT Analysis Conclusion**

Based on the City’s guidelines, the proposed Project, which consists of a maximum of 103,300 SF business park, satisfies Step 1: Transit Priority Area (TPA) Screening. Therefore, this project could be screened from a VMT analysis, and could be presumed to have a less than significant impact on VMT per the City’s guidelines.